

JIB LITE PRO

Jan 22

STANDARD JIB LITE PRO (6 ft/1.5m)

Supported Camera Weight 35 lbs (15.8 kg)

If you are missing any of the following items, please contact Stanton Video immediately (602) 493-9505

1. Rear Tube
2. Weight Bar
3. Center Tube
4. Front Tube
5. Pulley Cable
6. Camera Knob
7. Head Assembly
8. Expansion Joint Handle

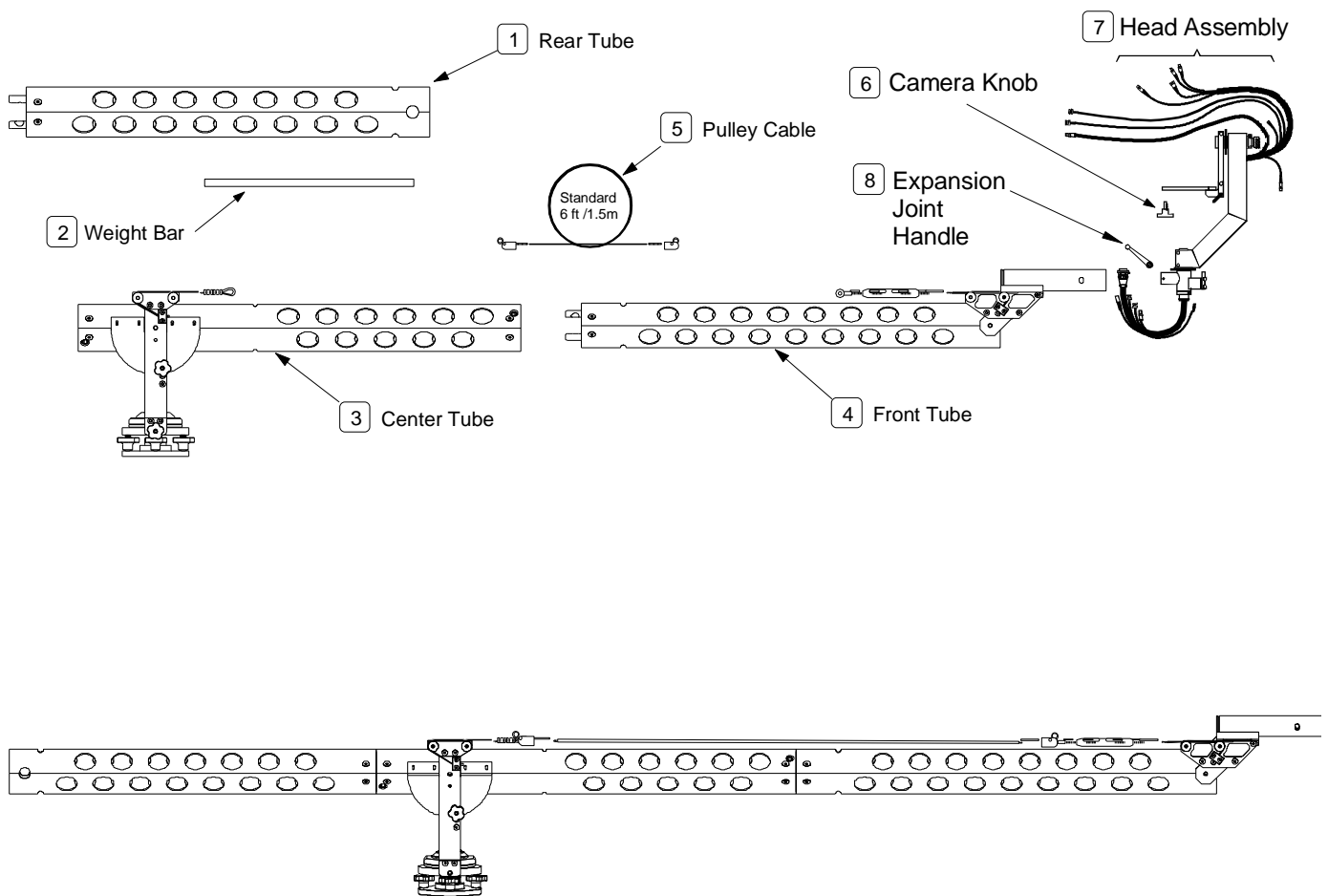

PRO LITE REMOTE HEAD KIT

If you are missing any of the following items, please contact Stanton Video immediately.
602 493-9505

- | | |
|--------------------------|----------------------|
| 1. Head Assembly | 6. Battery Charger |
| 2. Control & Battery Box | 7. Control Box Cable |
| 3. Joystick Handle | 8. Battery Cable |
| 4. Zoom/Focus Handle | 9. Control Cable |
| 5. Pan & Tilt Motors | 10. Follow Focus |

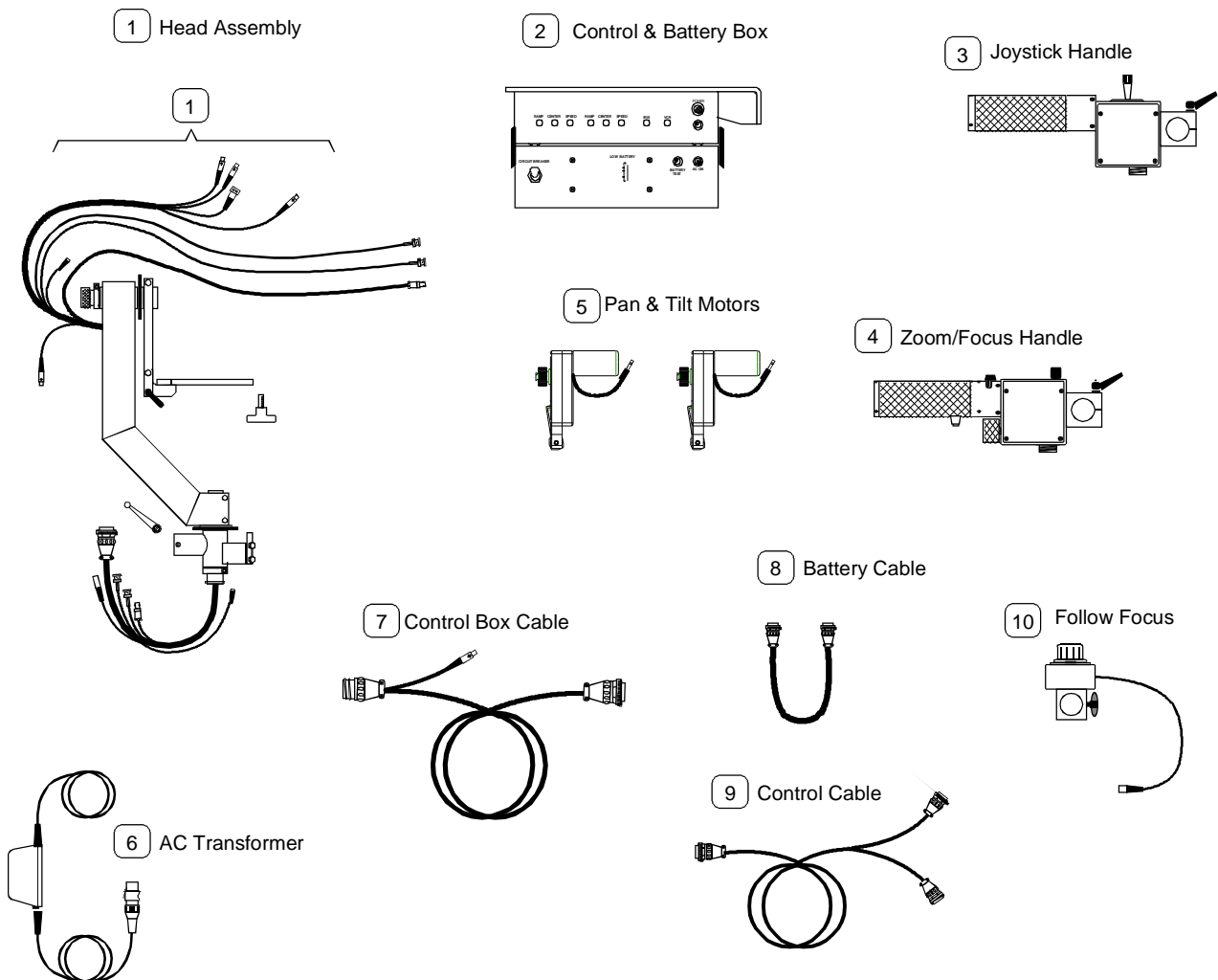

18 ft/4.5m UPGRADE KIT

Supported Camera Weight 35 lbs (15.8 kg)

- | | |
|------------------------------|---|
| 1. Extension Tubes (4) | 8. Giant Plus Strut Cable |
| 2. Rear Extension Tube | 9. Super Strut Cable |
| 3. Pulley Cables (4) | 10. Control Arm |
| 4. V-Strut & Knob | 11. Eye Bolts, Shackles, Threaded Knobs (2) |
| 5. Strut Cable Guide | 12. HDV Extension Cable |
| 6. Standard Plus Strut Cable | 13. 6 ft Head Extension Cable |
| 7. Giant Strut Cable | 14. 12 ft Head Extension Cable |

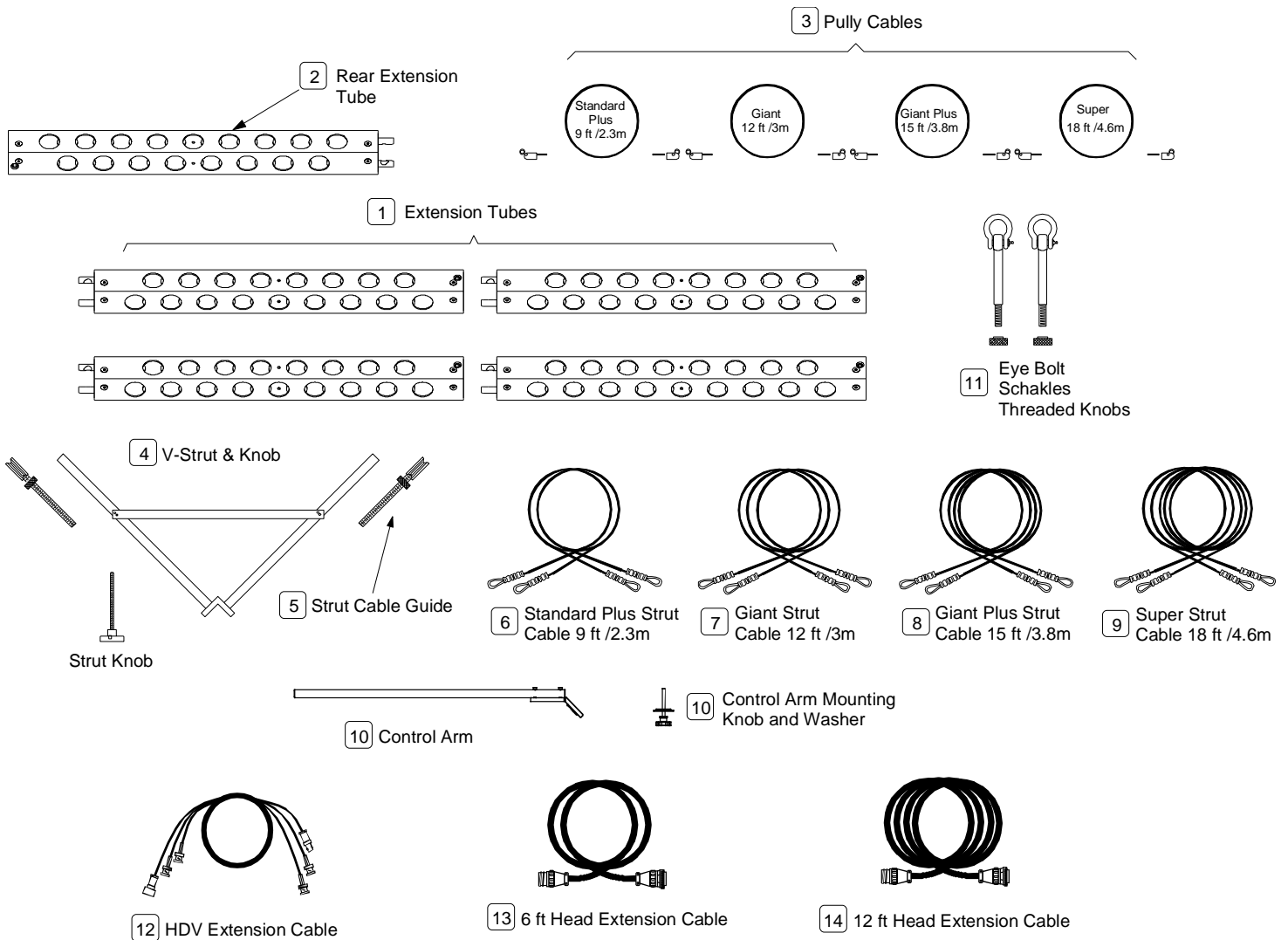

JIB ASSEMBLY
Standard Length

1. **Prior to attaching any tube section mating surfaces must be clean and free of any debris.**
2. Remove the Center Tube Section from the shipping container and mount it to your Tripod. Make sure the **Tripod Legs** and **Safety Clamps** are tight.
3. **Align a Tripod Leg with the Jib Tubes as you are assembling the Jib. This will prevent the jib from tipping during the assembly process.**
4. Attach the Rear Tube Section and secure it by locking the 2 cams using the ratchet provided.
5. Add Extensions and the Front Tube to the Center Section and lock the 2 cams.

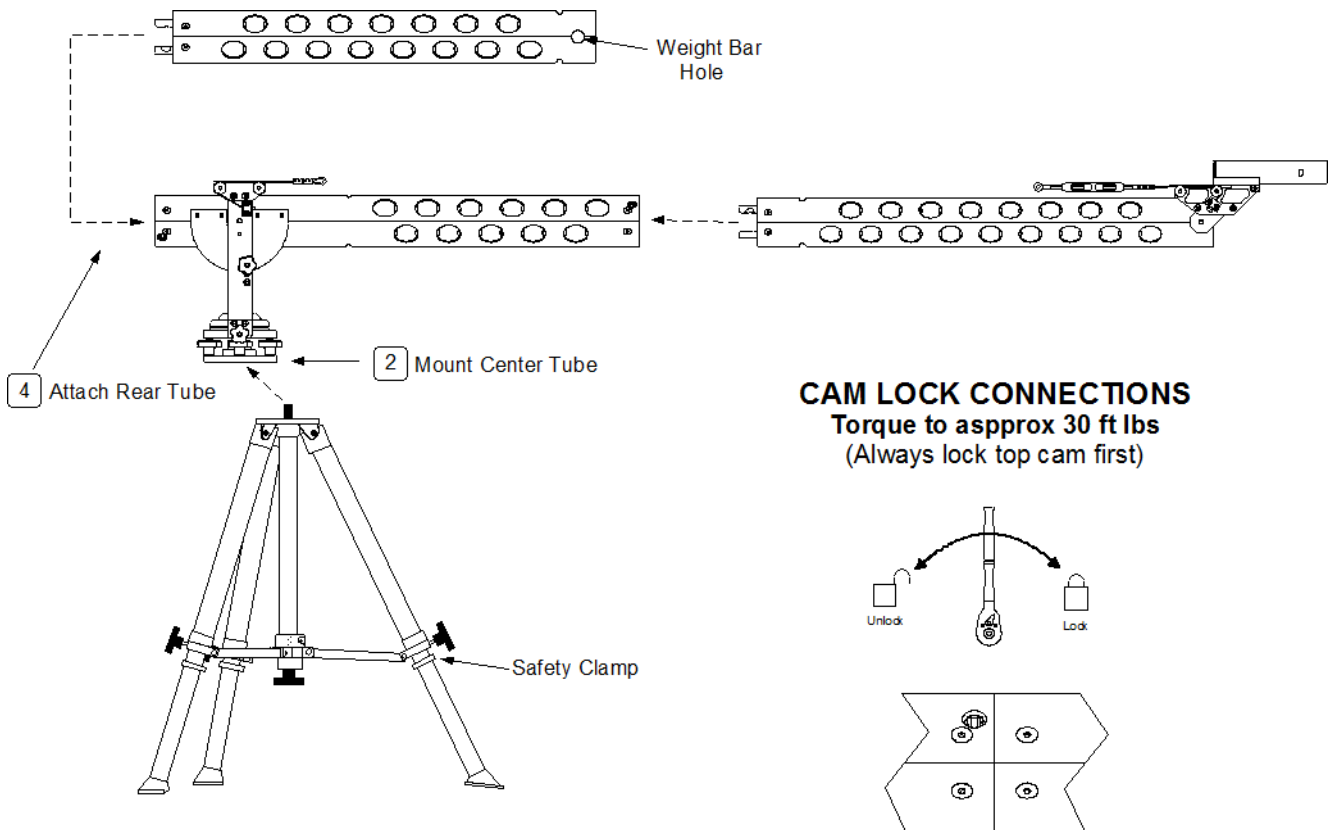

JIB LITE PRO TUBE CONFIGURATIONS



JIB LITE PRO STANDARD PLUS (9 ft / 2.3m)

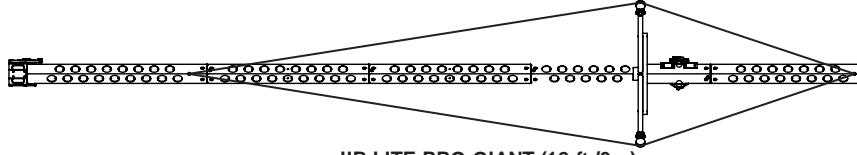

JIB LITE PRO GIANT (12 ft / 3m)

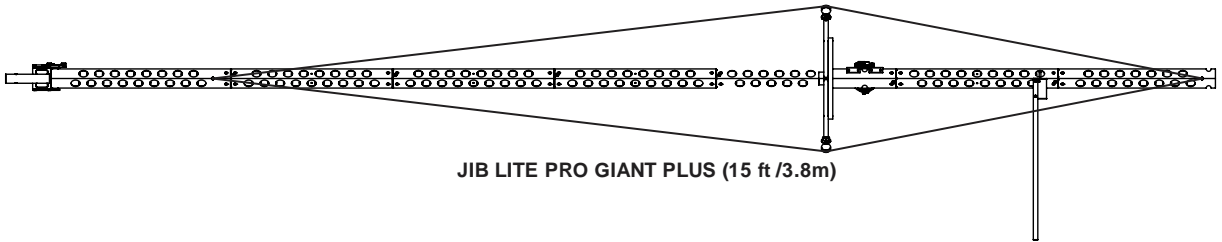

JIB LITE PRO GIANT PLUS (15 ft / 3.8m)

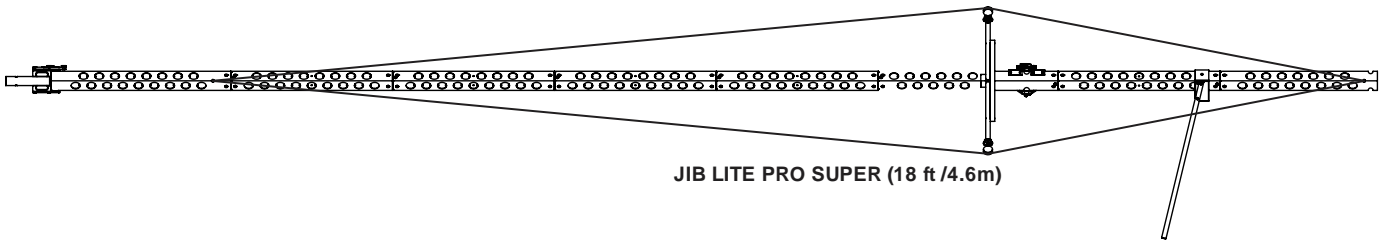

JIB LITE PRO SUPER (18 ft / 4.6m)

REAR CONTROL ARM POSITION

1. Secure Rear Control Arm using Washer and Knob as shown. Position for monitor viewing comfort.

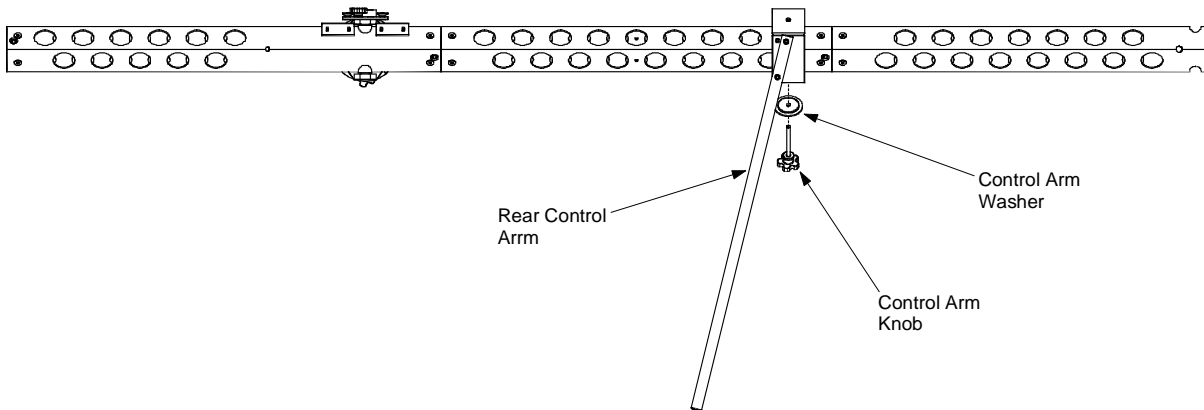

PULLEY CABLE

A steel wire rope cable (Pulley Cable) runs between the Pedestal and Front Assembly. This cable keeps the camera head level no matter what position the Jib arm is in. This is a good time to inspect the cable for breaks and frays. If any are found, the cable must be replaced.

1. Attach the Toggle Jaws to the wire rope and turnbuckle eyes. Make sure you insert the Safety Ring into the Pin.
2. The Pulley Cable must be properly aligned with the Cable Spools.

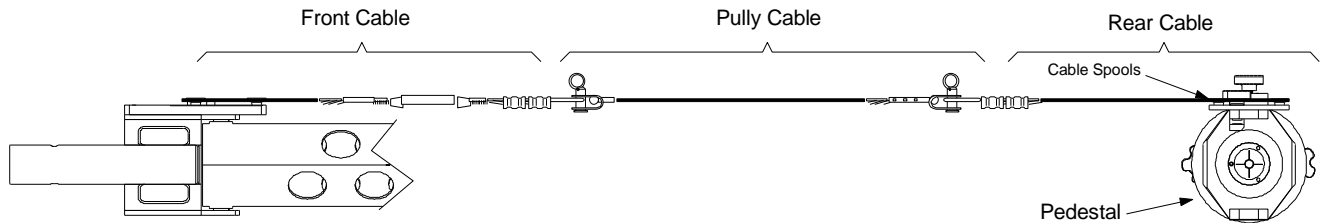

V-STRUT

1. Assemble the V-Strut
2. Attach the V-Strut to the Center Section using the Strut Knob and insert the Cable Guides into the strut tubes.

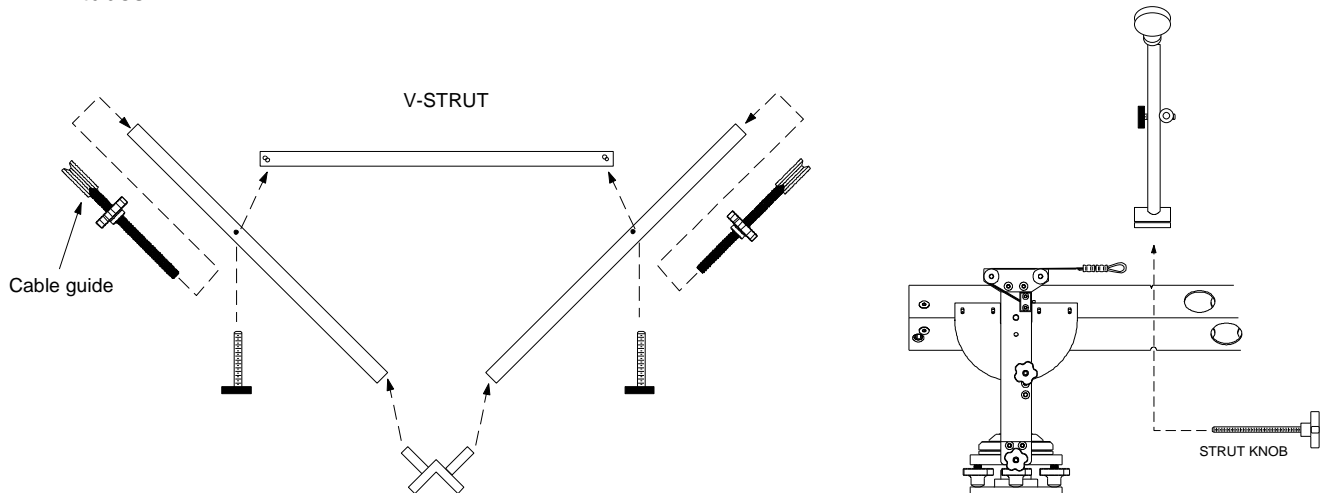

STRUT CABLES

1. Insert the Eye Bolts into the holes at the front and rear of the assemblies jib arm.
2. Attach the Strut Cables to the eye bolts with the provided Shackles. The same eye bolts are used on all jib lengths.

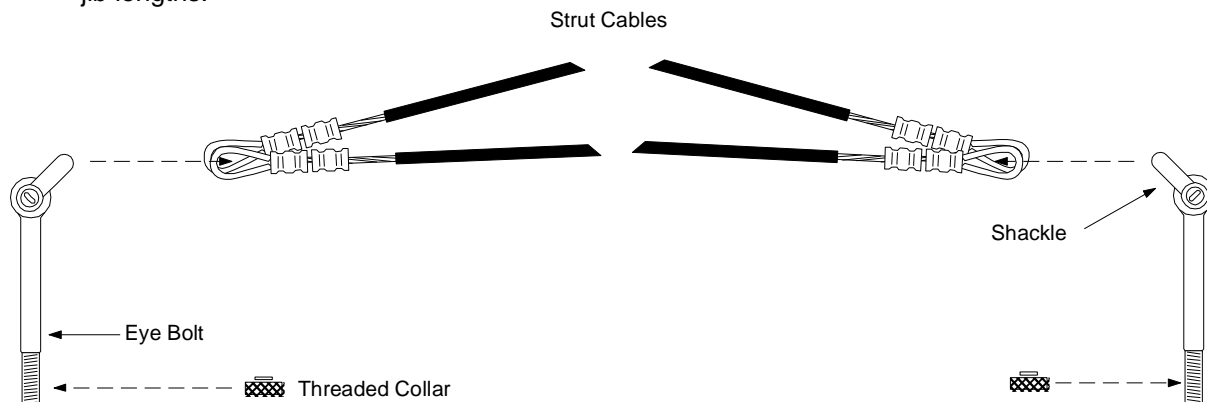

- Thread the Strut Cables through the Cable Guides. Adjust the guides if necessary

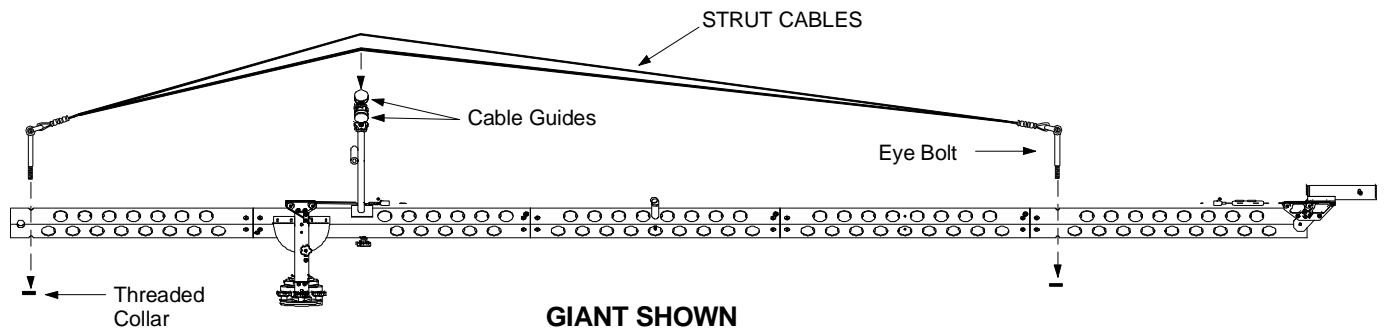

PULLEY CABLE STABILIZER

When the jib is extended to its full length the pulley cable will be unsupported for 18 feet. This will cause the cable to droop and sway when the jib is operated. This can be prevented by mounting the Cable Stabilizer using the holes provided in the extension tubes.

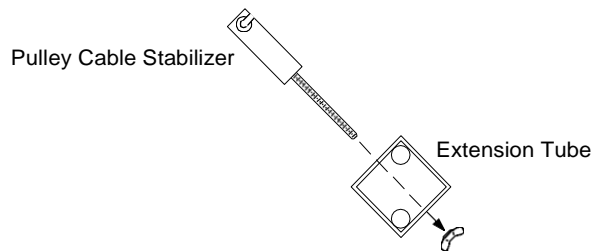

MOUNTING THE HEAD

- Use the Head Mounting Bolt to attach the head to the Head Mount Bracket and tighten with a wrench.

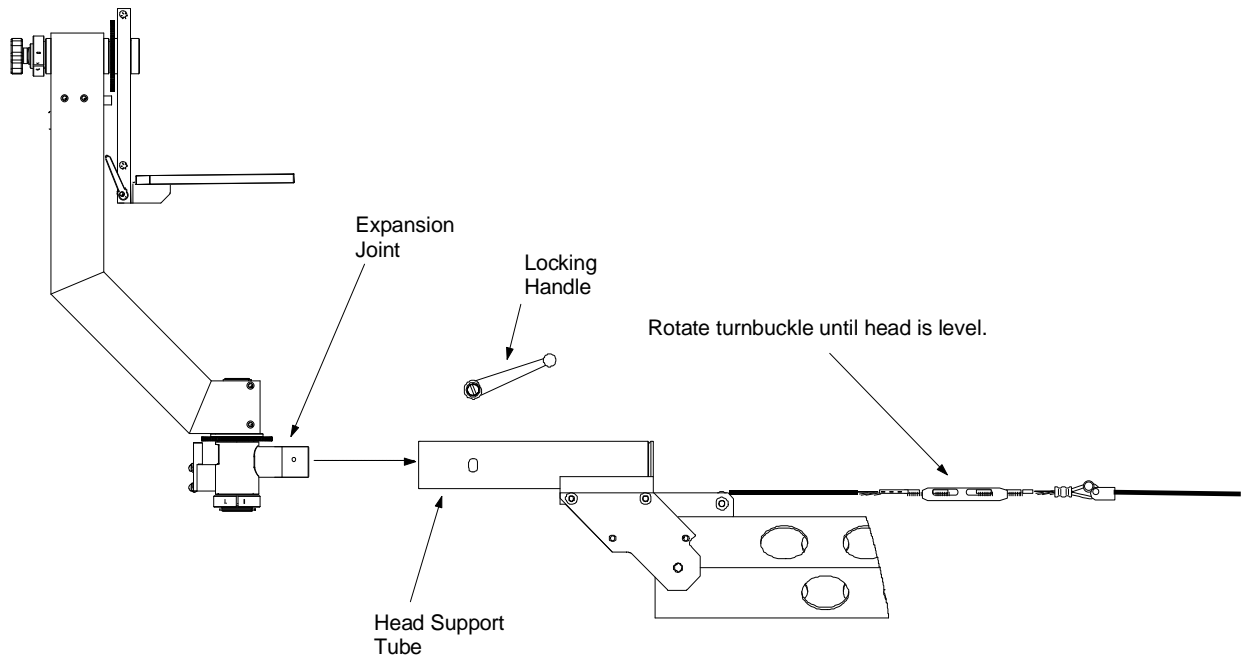

- After the Head is securely attached to the front of the Jib, **add some counter weight (25lb)** to the weight bar.
- Level the head by using the turnbuckle and the head mounting bolt

Note: Lifting up on the head will relieve tension on the turnbuckle and make it easier to adjust.

MOUNTING AND BALANCING THE CAMERA

NOTE: This is the most common "screw up" committed by users. This must be done properly or the Tilt axis will not work. Balancing means that the center of weight of the camera must be aligned with the center of Tilt.

HORIZONTAL BALANCE

1. Slide the camera platform to its lowest position and tighten the camera platform knob.
2. Configure your camera completely with the battery and zoom servo. Mount the camera to the camera platform with the camera knob.
3. Slide the camera forward or backward in the platform slot until the camera stays level. Tighten the camera knob.

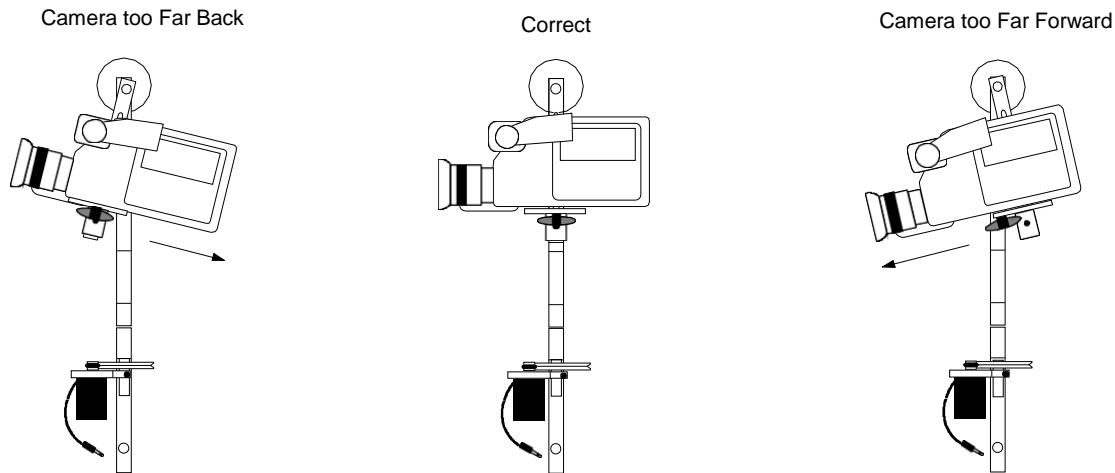

VERTICAL BALANCE

4. Slide the Camera Platform up the swing arm in 1/2 in. increments. The tendency of the camera to pendulum back to center will become less as it is moved up the swing arm.
5. When you reach the vertical balance point you will be able to rotate the camera to any position and it will remain in that position.
6. If you move the camera too high on the Swing Arm, it will try to rotate upside down.
7. Once you have found the correct platform position, make sure the Camera Platform Knob and Camera Thumbscrew are tight..

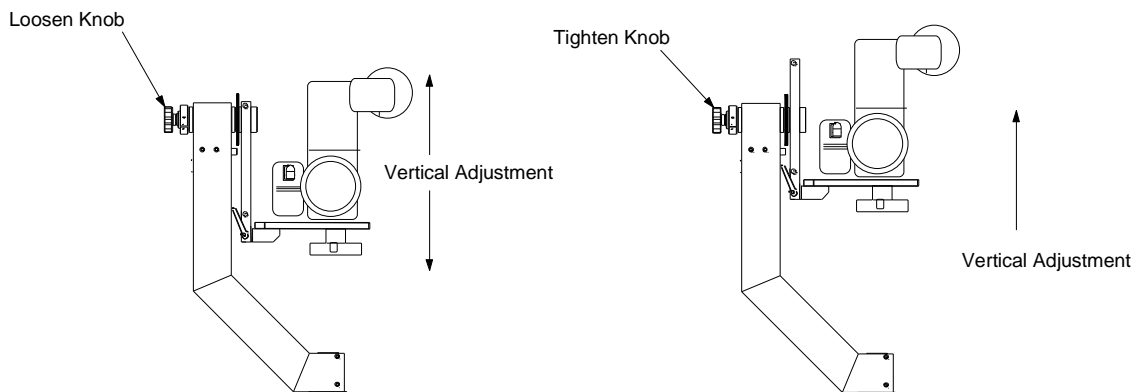

JIB COUNTER WEIGHT

1. Make sure all securing knobs for the camera, camera platform, jib mount and tripod legs are tight.
2. Use standard barbell weights (1 in. hole size). Olympic style weights are not recommended because the center hole is too large, causing the weights to be suspended below the jib centerline.
3. Start by loading 25 lb. plates on the weight bar, stacking them equally on both sides of the Rear Tube Section. Switch to lighter weights as the jib becomes more balanced.

CONTROL & BATTERY BOX

1. Attach the Control Box to the left side of the Pedestal (**use the bottom hole**) and secure with the provided Star Knob.
2. Attach the Battery Pack to the bottom of the Control Box. When the side latches engage, you will hear a snap if they have locked into position.

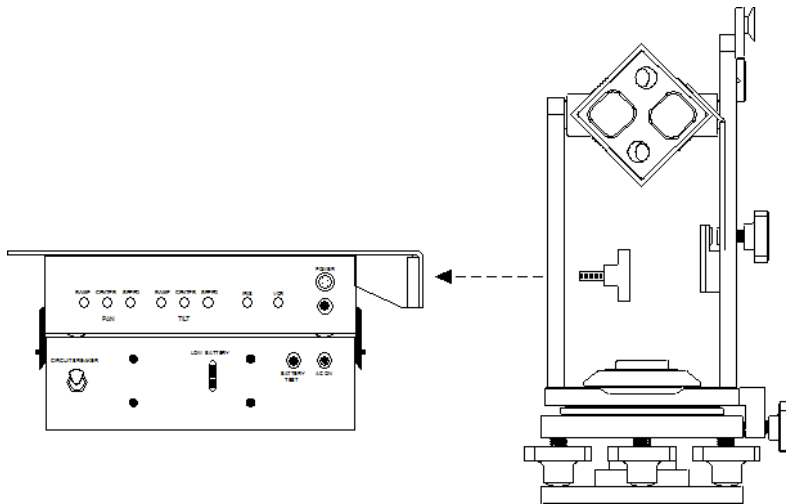

PAN & TILT MOTORS

1. The Pan and Tilt Motors are mounted to the Head through the use of a pin and a pinch type motor mount bracket.
2. Engage the motors by rotating them into the 4 in. gear and tightening the pinch clamp .

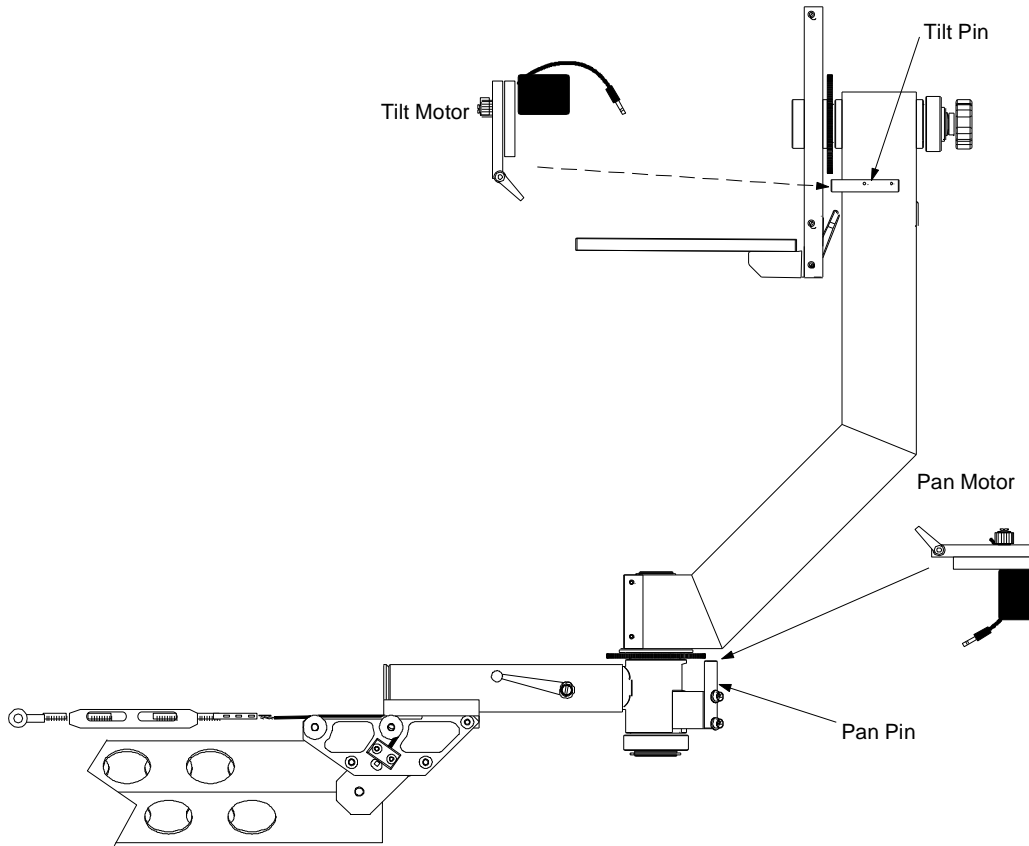

PAN & TILT SLIP CLUTCH

NOTE: The most common mistake made by first time jib users is the improper balancing of the camera. If the camera is out of balance, the strain on the Tilt Motor will cause the motor clutches to slip. This is a safety feature. The Clutches prevent damage to the gear motor when inverting or moving the Head manually with the motors engaged.

The clutch friction should be high enough to allow the motors to pan or tilt the camera but still have enough slippage to allow the head to be moved manually. If the clutches are slipping (during normal joystick operation) and you are sure you have balanced the camera properly, it may be necessary to increase clutch tension. The clutch adjustment screw is locked with a set screw which prevents the screw from turning when the gear slips. To increase friction turn the screw clockwise in small increments

It has been found that the use of the small 22 tooth pinion on the Tilt Axis has improved the "feel" and movement of this Axis. This is especially true when using heavier film cameras. This small pinion is available as an accessory.

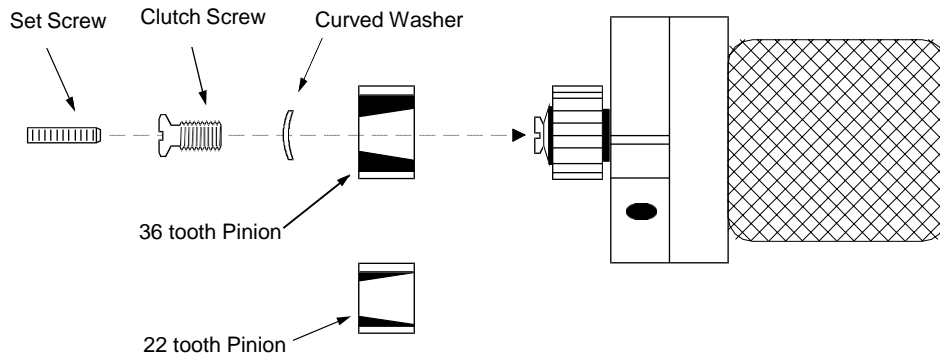

FOCUS & IRIS MOUNT

The Focus/Iris assembly consists of two servos with gear wheels attached. This assembly mounts to the screw hole utilized by the lens manufacturer to mount their cable drive focus systems. As you tighten the Lens Mount Knob to mount the assembly, you must be careful that the screw does not bottom out inside the lens. If you continue to force the screw you may do internal damage to your lens.

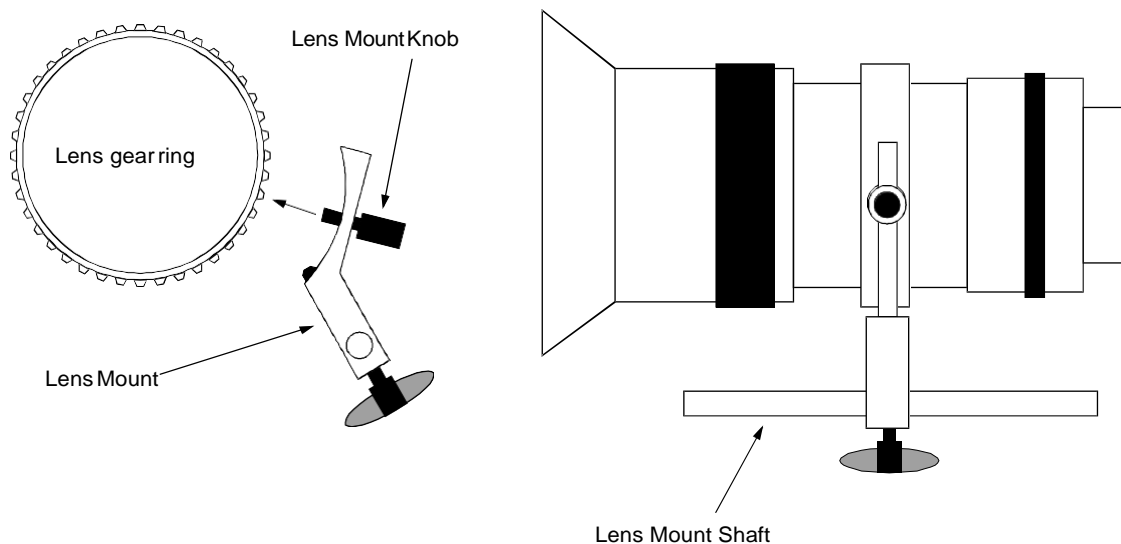

Occasionally the curvature of this mount is greater than the lens curvature. This means that there will be contact only at the center of the mount instead of along the entire curve. This can cause the Focus/Iris assembly to twist on the lens. To correct this problem, adjust the set screw in the Lens Mount. Back out this set screw only far enough to just touch the lens.

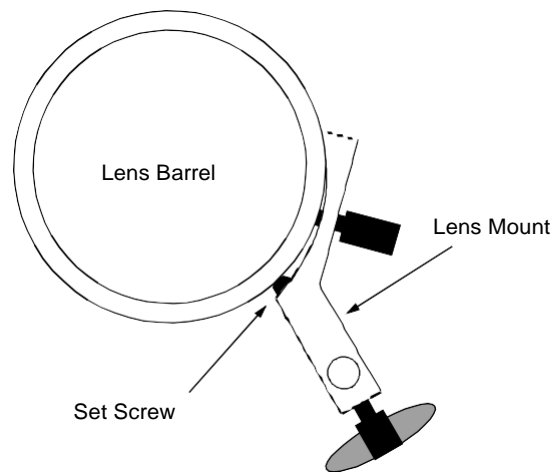

IRIS SERVO

1. The lens auto iris switch should be in the off position.
2. Slide the Iris Servo onto the Lens Mount Shaft and plug the servo into the proper (blue) connector. **Turn the unit on.**
3. Rotate the Lens Iris clockwise (iris closed) until you hit the lens stop. Rotate the Iris Servo gear (using the Iris Knob on the control box) counter clockwise until you hit the servo stop. This will synchronize the Lens and Servo stops.
4. Engage the Iris Servo with the Lens by rotating the Iris Servo on the Lens Mount Shaft. Lenses with extenders may require the Iris Servo to be reversed in its mount.

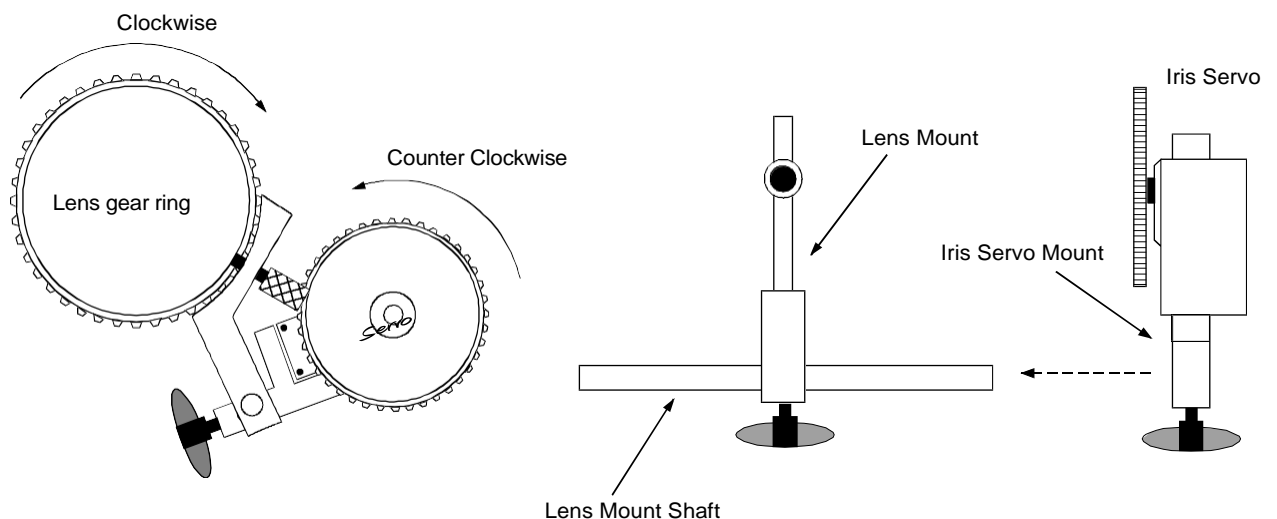

FOCUS SERVO

1. Slide the Focus Servo onto the Lens Mount Shaft and plug it into the proper (red) connector.
2. Rotate the Servo on the Shaft until the Lens Focus Gear ring and servo gear engage.
3. The Focus Servo Bracket is spring loaded. Compress this spring slightly when you engage the gears.

If you have a Canon Lens, the Master Gear will directly engage the lens. If you have another lens it will be necessary to add an extra gear. Slip the extra gear over the hub of the Master Gear and secure with the 4-40 screw.

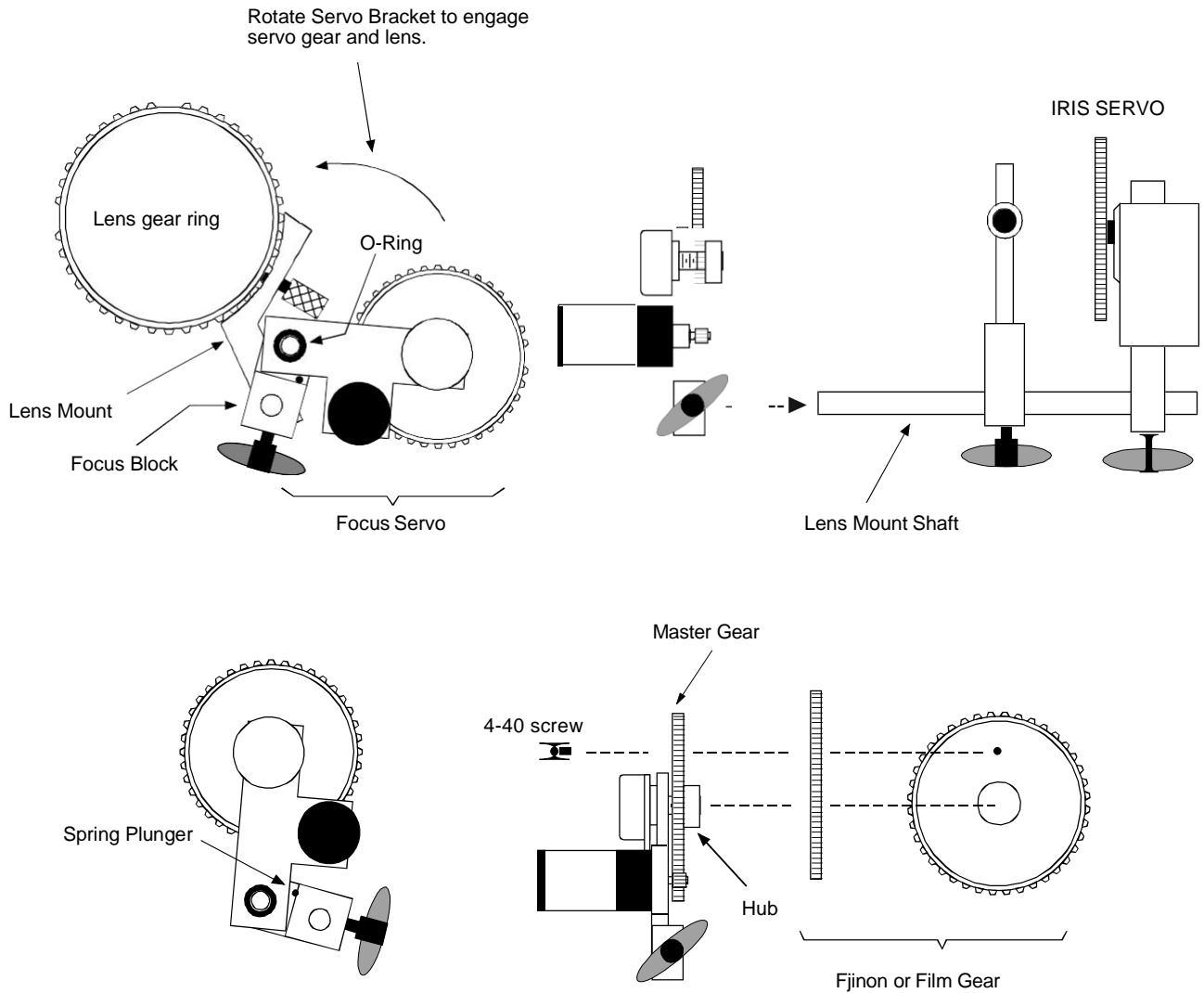

The Focus Block can be placed in multiple positions to facilitate mounting the Focus Servo to a variety of video lenses and cameras. The o-ring holds the focus block in place. While inserting the focus block into its new location, the Spring Plunger must be depressed with a small screw driver.

The Focus Servo can be mounted to 15mm matte box rods by removing the Focus Block and replacing it with a 15mm Focus Block. This is an accessory available from Stanton Video.

Focus Rotation Focus rotation is set at the factory at about 90°. This will usually be more than enough for most video lenses. If you need to increase focus rotation refer to the last page under PC Board Adjustments. You should call Stanton Video before making this adjustment.

FOLLOW FOCUS SYSTEM

1. **Follow Focus Box:** The Follow Focus allows an assistant to pull focus when necessary. This is achieved by plugging the Follow Focus Box into the Zoom-Focus Handle.
4. **Set Point Switch:** This switches focus control from the Focus Knob on the bottom of the Handle, to the Follow Focus Box. This allows you to rack focus between two focus set points by using the follow focus as a memory position.
5. **Focus Rate:** Is used when switching between focus set points. This pot controls the elapsed time to perform the focus.

NOTE: The Set Point Switch transfers focus control back and forth between the Focus Handle and the Follow Focus Box. If the follow focus is not connected and the switch is in the wrong position the focus control on the handle will not work.

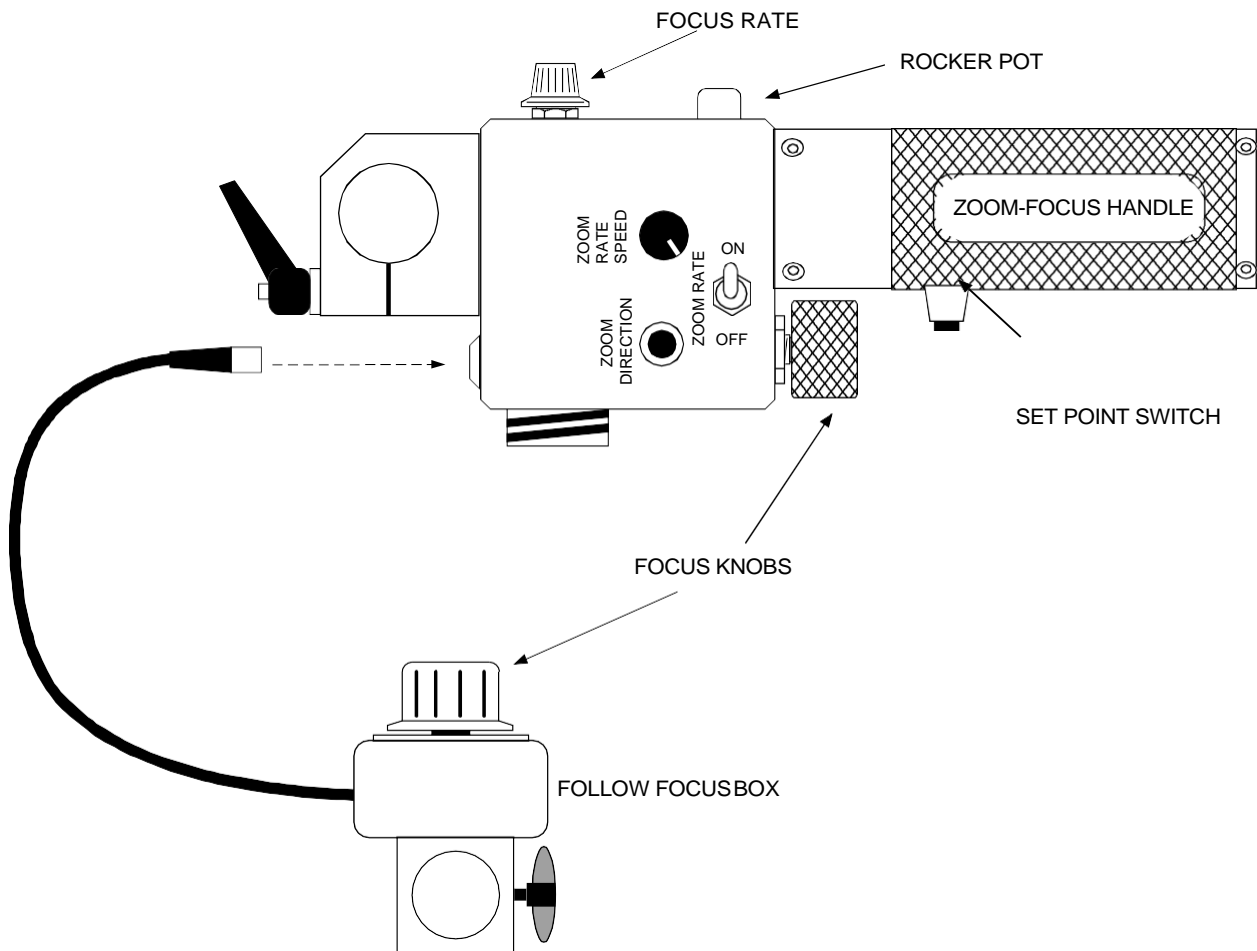

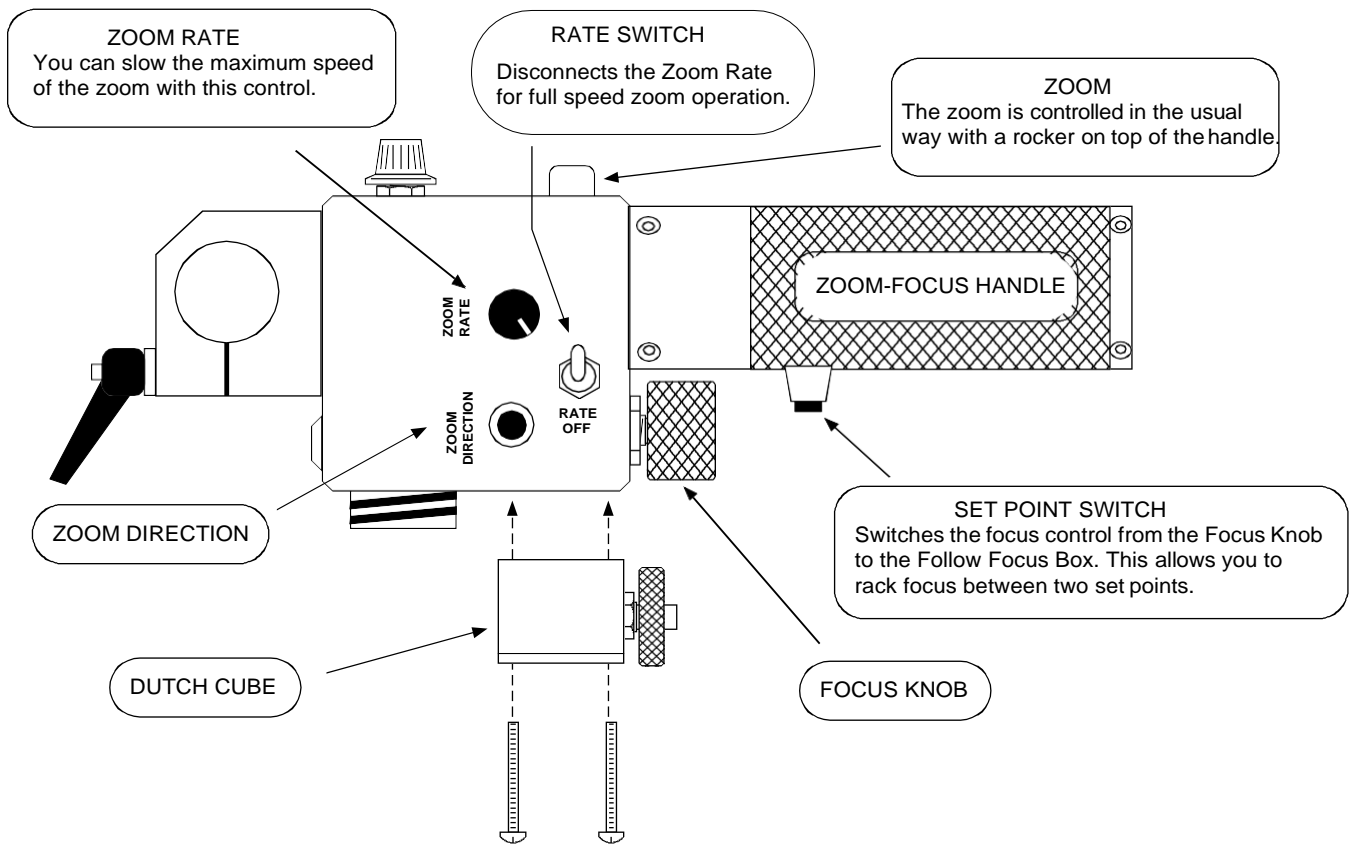
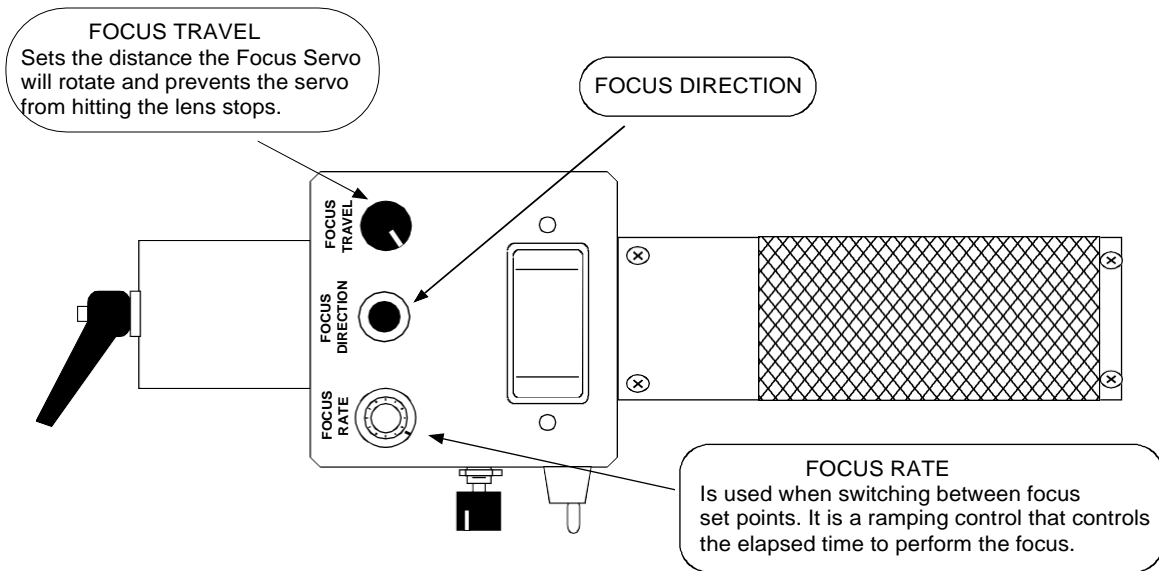

* To use the optional Dutch Cube, follow the instructions below:

1. Attach the cube to the zoom/focus handle (or the joystick) with the two attachment screws.
2. Plug the connector into the external jack on the Dutch Controller until the Cube is activated.
3. Cycle the selector button on the Dutch Controller until the Cube is activated.

Note: It is also possible to plug the Cube into the external jack on the Focus Handle and utilize it As an extra focus control.

Note: **For users with an older system upgrading to new controls:** The new control handles may be used with any Model 4 control box but you must purchase a new Control Cable and make a wiring change in the control box. After the wiring change, your old controls **will not be compatible**.

JOYSTICK HANDLE

You can change the joystick control from a thumb operated style to a more conventional setup with the Joystick extension. Remove the four attachment screws, take off the handle and then push on the longer extension.

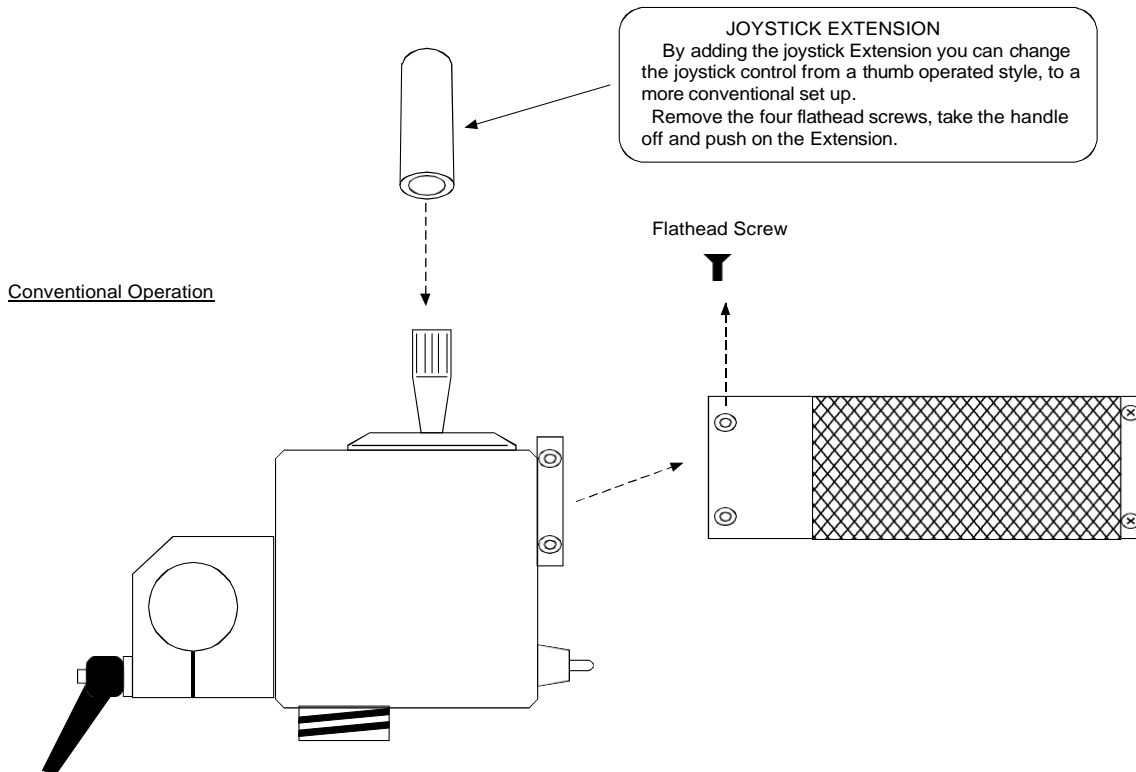
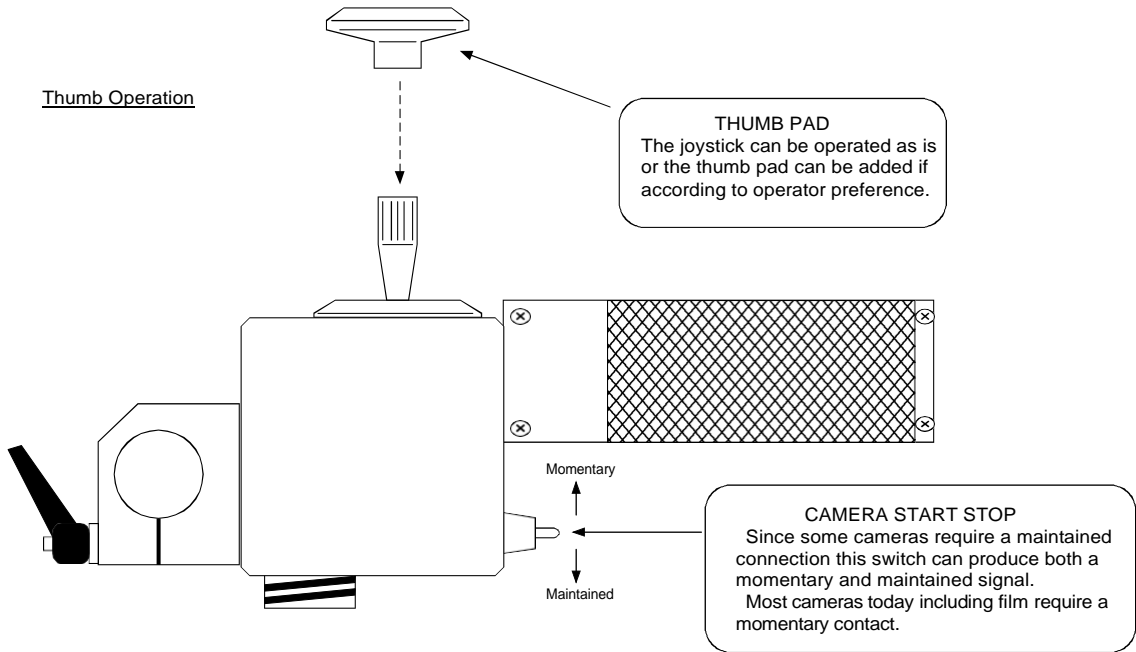

HOW TO ELIMINATE ZOOM CREEPING

(New 4B controls)

There are two possible situations that can cause a creeping zoom problem. One is that the lens switch on the back of the control box is in the wrong position and the other is due to natural variations from lens to lens. Lens to lens variation can be corrected by adjusting a trim pot inside the Zoom Handle. It is extremely important that the lens switch be put in the correct position before the trim pot is adjusted. Please follow the instructions below to insure proper setup.

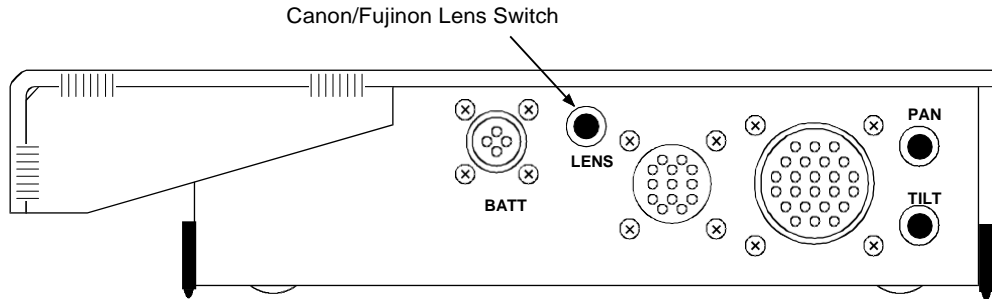

Lens Switch

1. Turn the camera on and observe how the lens responds. Rotate the Zoom Rate from minimum to maximum. If you can zoom the lens in and out using the Zoom Rate control then the lens switch is in the wrong position.
2. Once the lens switch is in the correct position the lens should work normally except for the creeping.

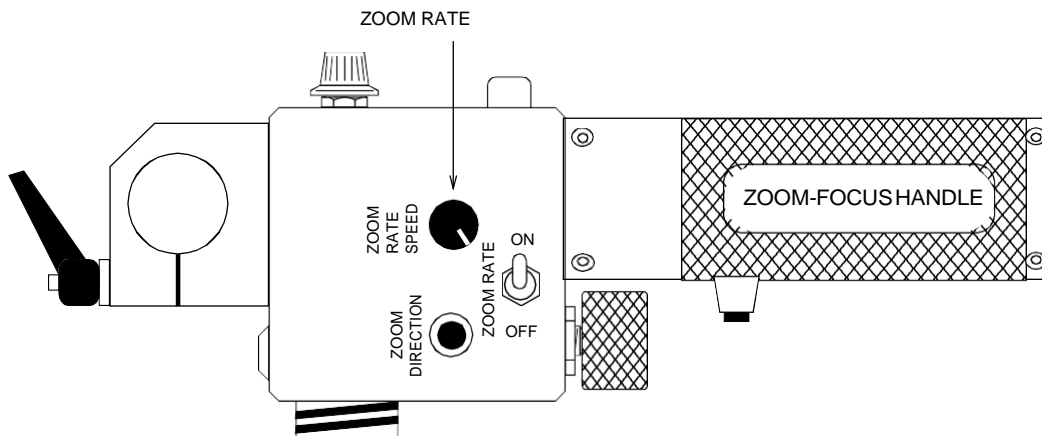

ELECTRICAL CABLE ROUTING

THE UNIT SHOULD BE TURNED OFF BEFORE MAKING ANY CONNECTIONS

HEAD CABLE & CONTROL CABLE

1. Connect the Focus Motor (red) and the Iris Motor (blue) using the 4 pin Switchcraft connectors.
2. Connect the Tilt Motor (blue) and Pan Motor (red) using the phono plugs.

CONTROL CABLE

1. Slide the weight bar into the Rear Boom Section. Attach the Joystick and Zoom/Focus Handle to the weight bar.
2. Plug the 16 pin Amp connector of the Control Cable into the Control Box and route it down the Rear Tube section toward the weight bar.
3. Connect one end of the Control Cable (blue) to the Joystick and the other end (red) to the Zoom/Focus Handle.

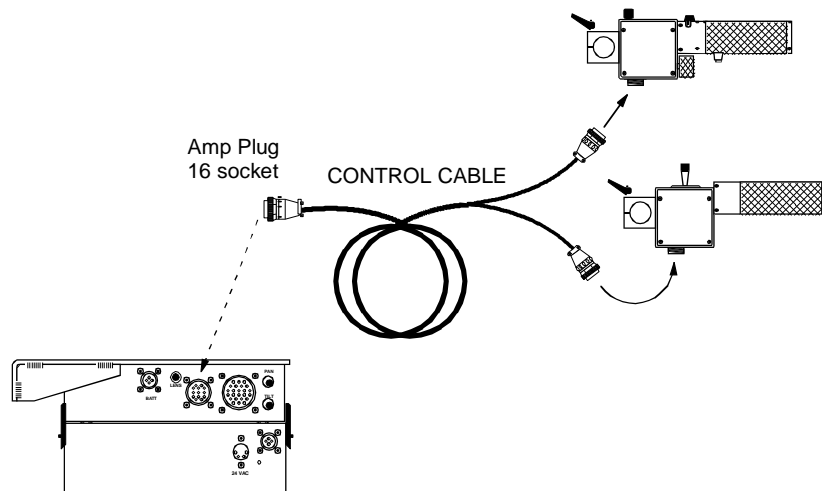

CONTROL & BATTERY BOX

1. The lid of the Control Box is also the monitor platform.
2. Attach the Battery Pack to the bottom of the Control Box. When the side latches engage, you will hear a snap if they have locked into position.

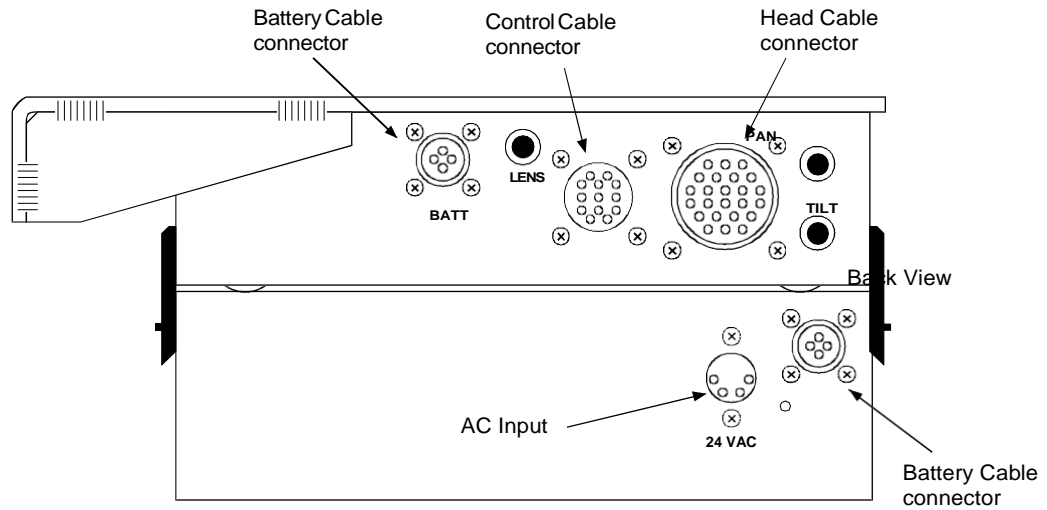
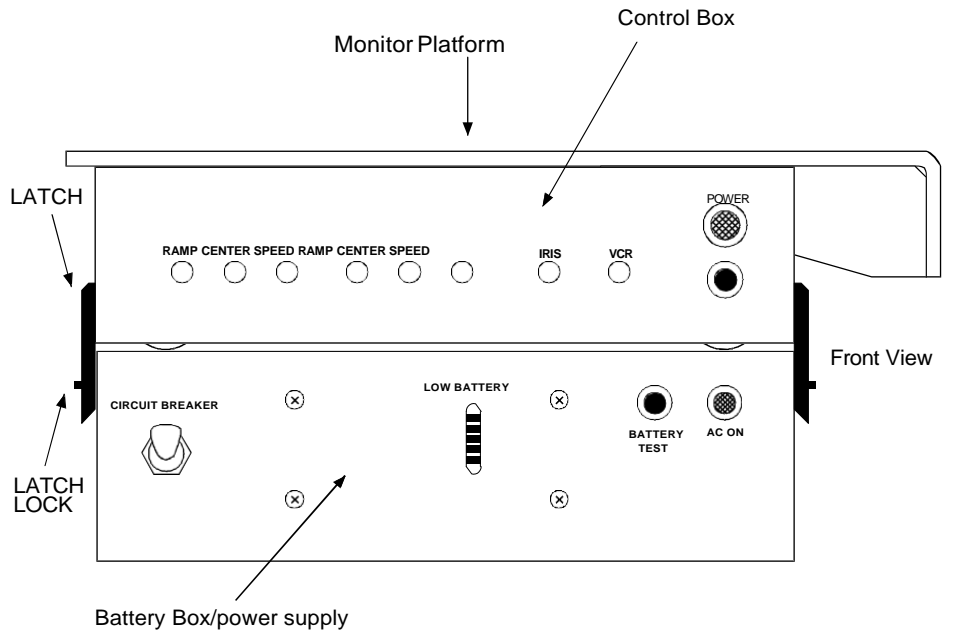

ELECTRONIC CONTROLS

1. Ramp: An adjustable acceleration ramp that cushions the start and stop of the pan and tilt motion. The amount of cushion is increased by rotating the "Ramp" knob clockwise.
2. Center: Sets the pan or tilt output voltage to zero. This is set at the factory and under normal circumstances does not require operator adjustment. If you observe the head moving without deflecting the joystick, it will be necessary to adjust centering.
 - a. Disengage the motors from 4 in. gears.
 - b. Adjust the RAMP to minimum and the SPEED to maximum.
 - c. Position the head so that you can observe the motor pinion.
 - d. Adjust the centering control until the gear stops moving.
3. Speed: Controls the maximum speed for pan and tilt. This makes the joystick less sensitive and is most useful for slow accurate moves.
4. Iris: Controls the iris.
5. VCR: Starts and stops the VCR providing your lens connector allows for this. Make sure the VCR switch on your lens is in the off position. Since most newer cameras require a momentary contact this is the type of switch that we have provided. If your recorder requires a maintained switch you will have to start and stop the recorder at the camera.

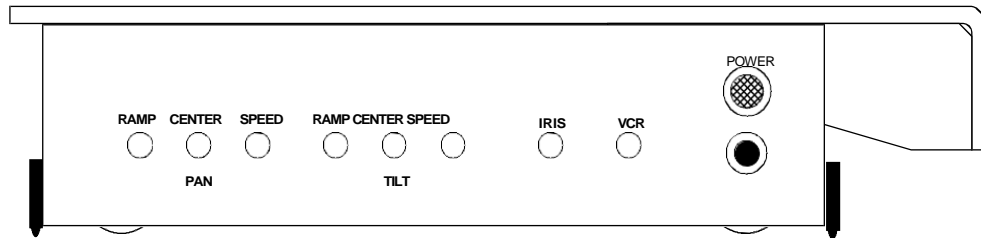

6. Lens: By pushing this switch you change to Canon or Fujinon. If your lens does not work properly this switch is probably in the wrong position.
7. Polarity: This switch enables you to change direction of the Joystick to whatever "feels" most comfortable to you. When you under sling the head it will be necessary to change pan direction.

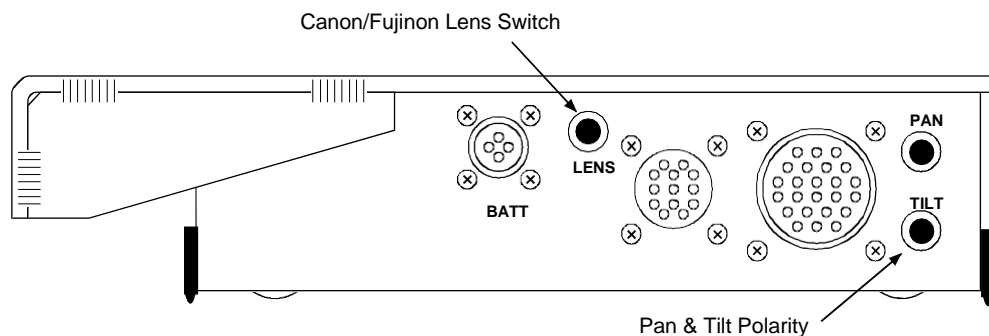

QUIETDRIVE LUBRICATION

The following instructions describe the proper lubrication of the Quiet Drive gear motor. To prevent belt slippage the belt must be coated with some type of belt dressing. The critical point that must be remembered is that grease must not get onto the belt and you must not put so much grease into the gearbox that it gets thrown on the belt.

BELT DRESSING

We have found that JP1 Chain Lube (blue can) works the best as a belt dressing. This substance becomes very tacky without gluing the belt to the pulleys as some of the regular belt dressings tend to do.

1. Remove the Motor, the Pulley and the belt from the gearbox. If the belt has been slipping thoroughly clean the pulleys and belt with alcohol.
2. Coat the Belt and the grooves of the Pulleys with the dressing. Set these parts aside to dry for about 30min.

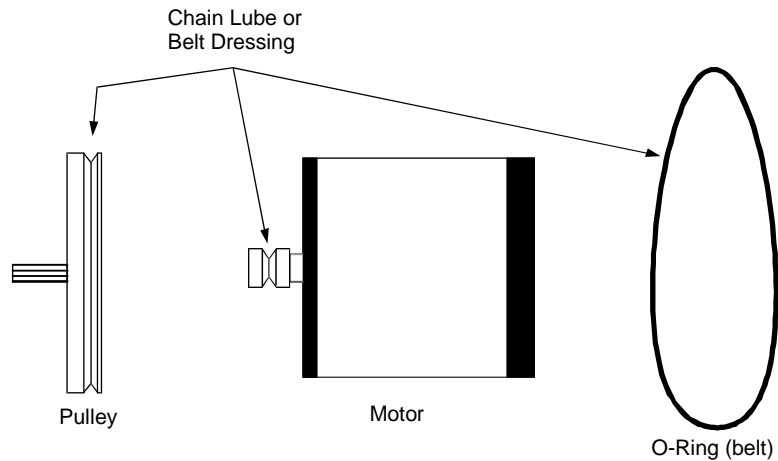

3. Mount the motor to the gearbox with the two 4-40 Philips screws and slide the tiny washer onto the Pulley Pin.
4. Add a small amount of grease to the Pulley Pin, slide the tiny washer onto the pulley pin, then add another small amount of grease to the Pulley Pin and slide the Pulley onto the Pulley Pin.
5. Run the Belt between the two pulleys taking care not to allow grease onto the Belt from the pins.

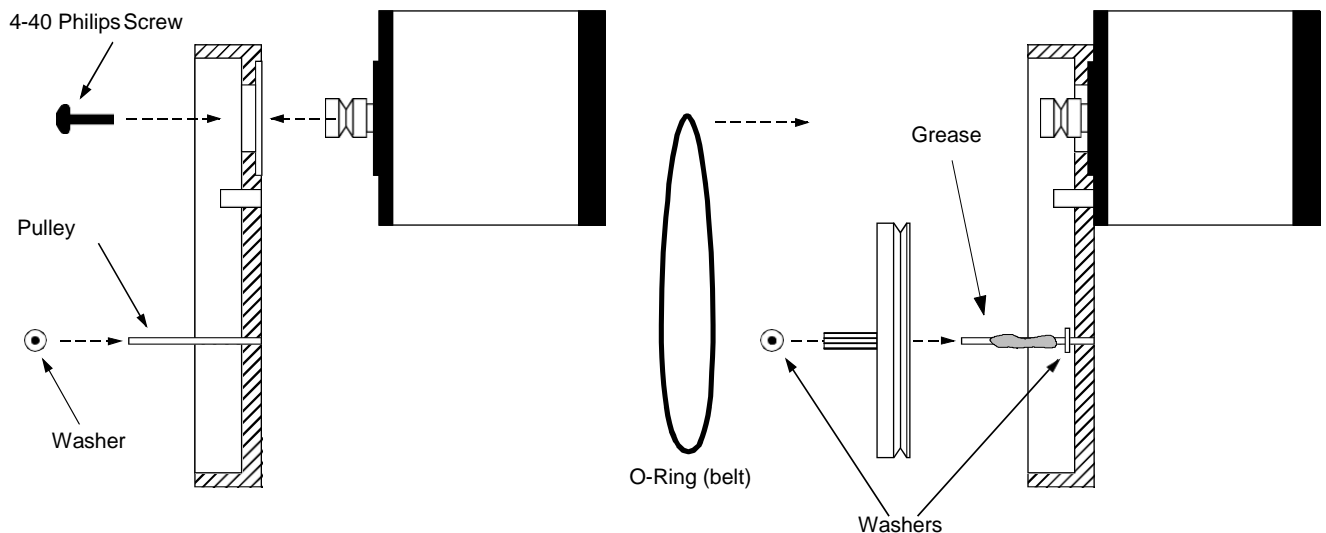

- Add the thin washer to the Shaft Pin.
- Place grease into the hole in the rear of the Shaft and grease the teeth of the Gear. Push the Shaft onto the Shaft Pin. It will be necessary to push until the Shaft seats against the back of the gearbox.

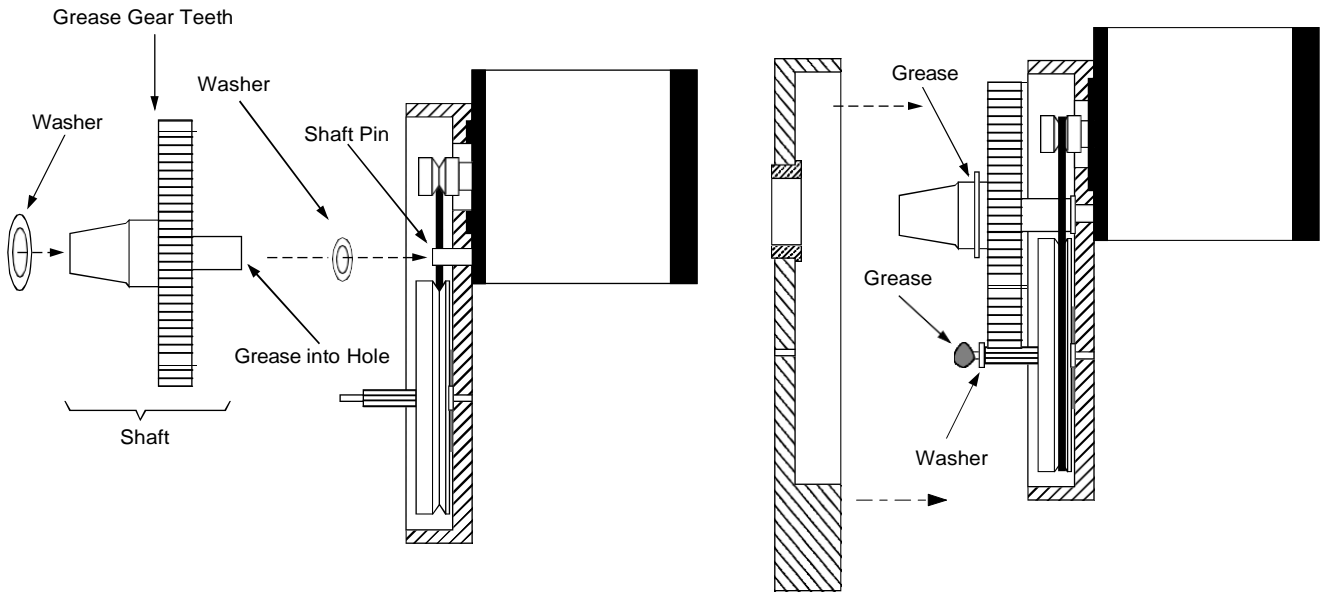

- Place the tiny washer onto the Pulley Pin and grease the end of the Pin. Apply grease lightly to both sides of the large thin washer, install washer on the gear on the Shaft and close the gearbox.

NOTE: The lubricant used should be a non melting high temperature type of grease.
The Belt is an O-ring that is 2" OD with a 1/16" cross section.

CHARGING VOLTAGE ADJUSTMENT

- The unit must be fully charged before making any adjustments.
- Turn charger on and check voltage across pins 1,2 & 3 at the 4 pin AMP connector on the Battery Box.
- Turn the Adjustment Pots to attain 14 Volts between pin 1 & 2 and 14 volts between 2 & 3.
- After you have adjusted the two pots, measure the voltage between pin 1 & 3. It should be about 28 volts.

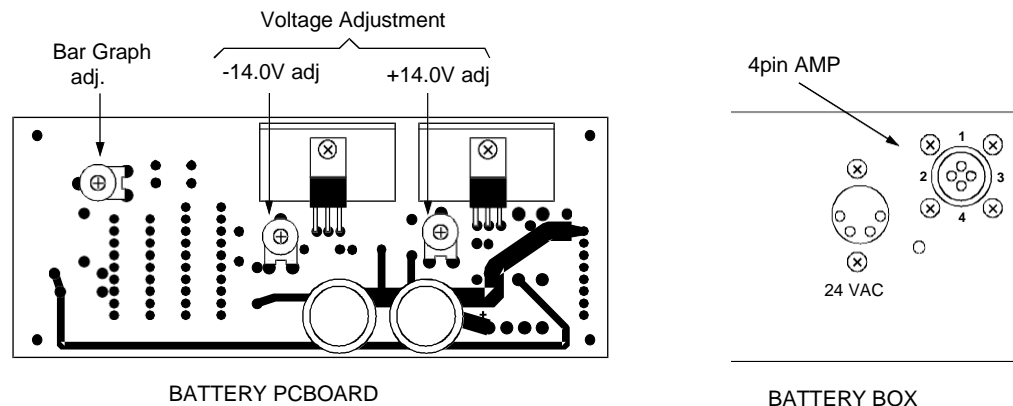

CIRCUIT BOARD SET UP ADJUSTMENTS

Focus Rotation Angle

1. The Angle Pots allow you to increase focus rotation. The factory setting is minimum (about 90 deg.).
2. To increase the Focus Rotation Angle turn the Angle Pot counter-clock wise.
3. Maximum is about 250 deg. If you over adjust the pot, the focus motor will continuously rotate in one direction.

+5 Volt Adjustment

1. Connect a voltmeter from gnd to -5 V and measure the voltage. This measurement will usually be about -4.97 volts.
2. Connect the voltmeter from gnd. to +5 V.
3. Rotate the +5 Volt adjust. until the meter reads the same as the -5 V measurement. The goal is to make both the +V and -V read the same.

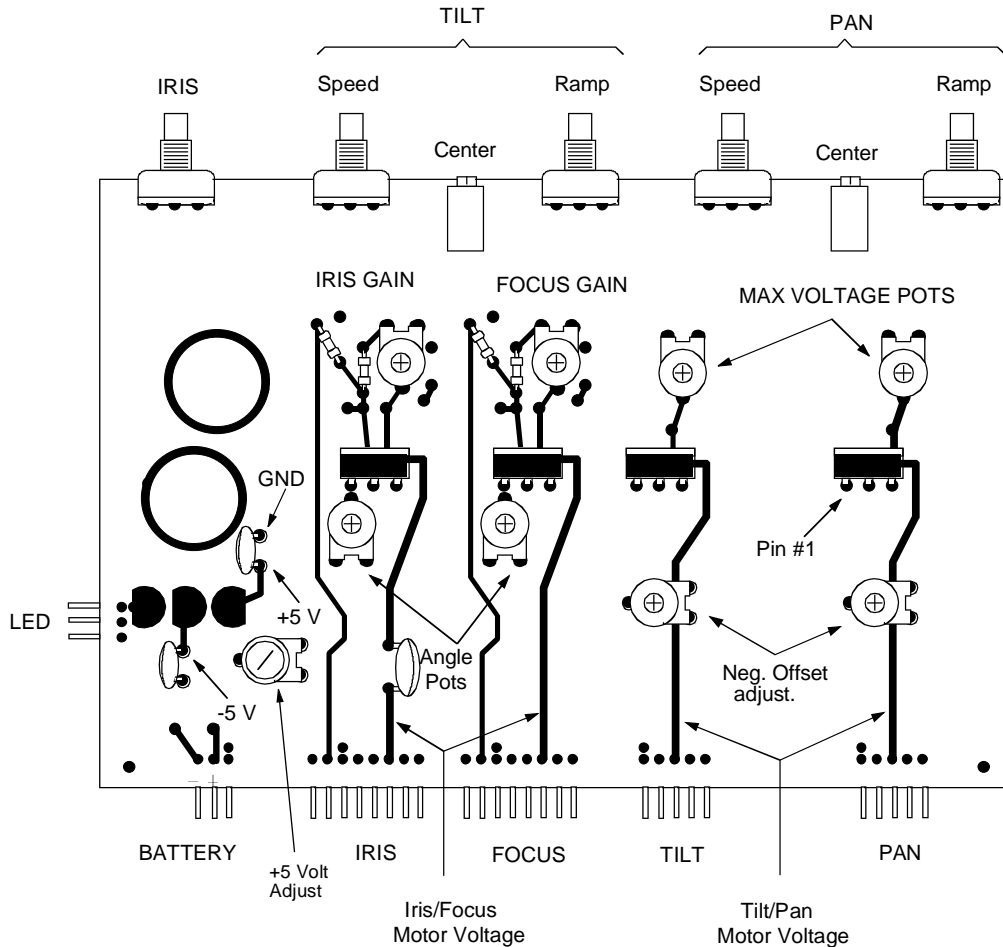

Negative Offset

1. Turn the Speed pot all the way down (counter clockwise).
2. Turn the Ramp pot all the way down (counter clockwise).
3. Connect Pin #1 of the Op-Amp to gnd. with a jumper cable.
4. Connect a voltmeter from Pan/Tilt Motor Voltage to gnd.
5. Rotate Neg. Offset Adjust. until the meter reads as close to Zero voltage as possible.

Maximum Voltage

1. Connect the voltmeter from gnd. to Motor Voltage.
2. Power unit from AC (connect to battery pack and turn on charger).
3. Deflect the Joystick (maximum deflection) of the axis being adjusted.
4. Rotate Max. Voltage pot until meter reads minimum voltage. Now rotate pot in the opposite direction and stop when the motor voltage ceases to increase

HEAD PARTS

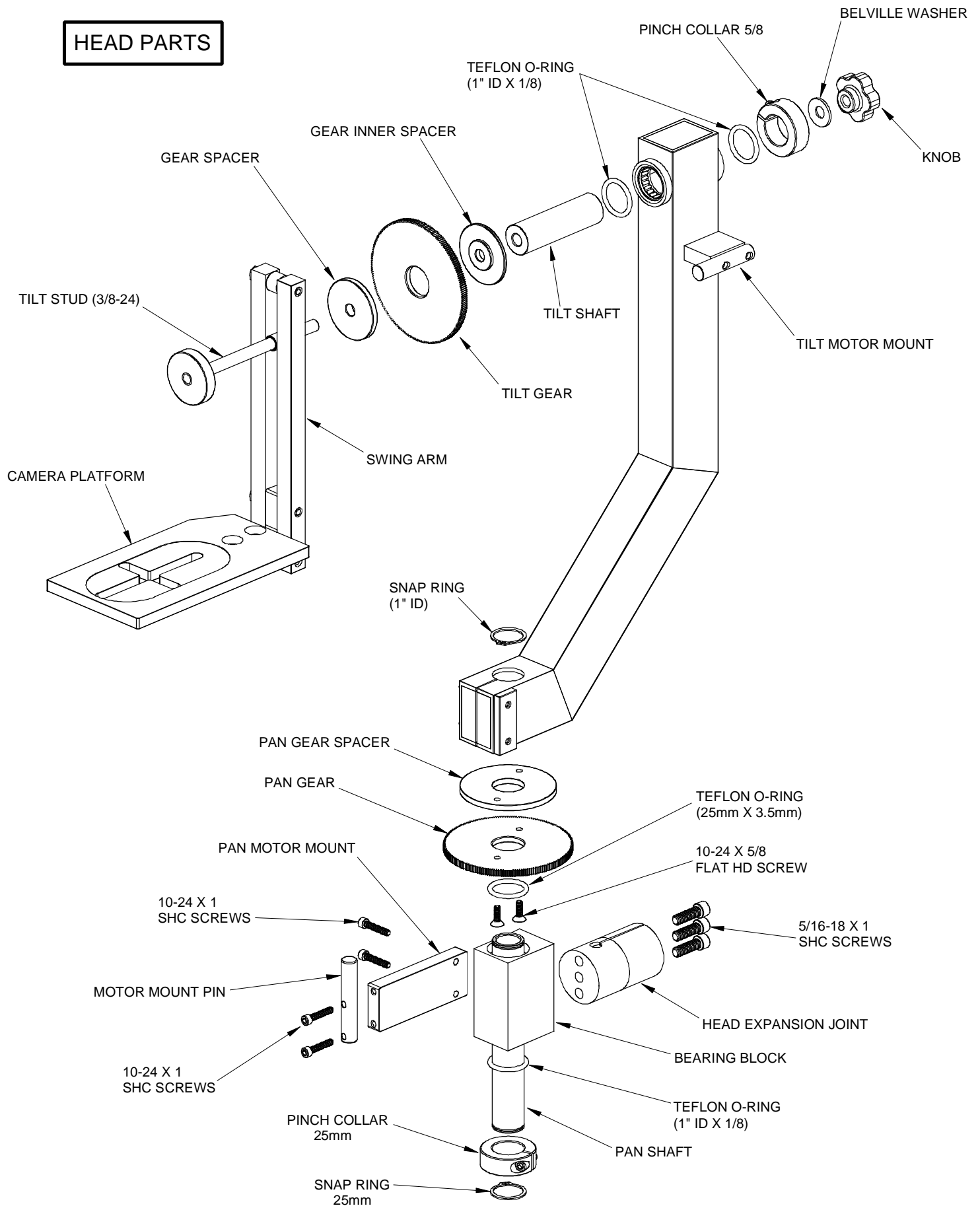

UPRIGHT PARTS

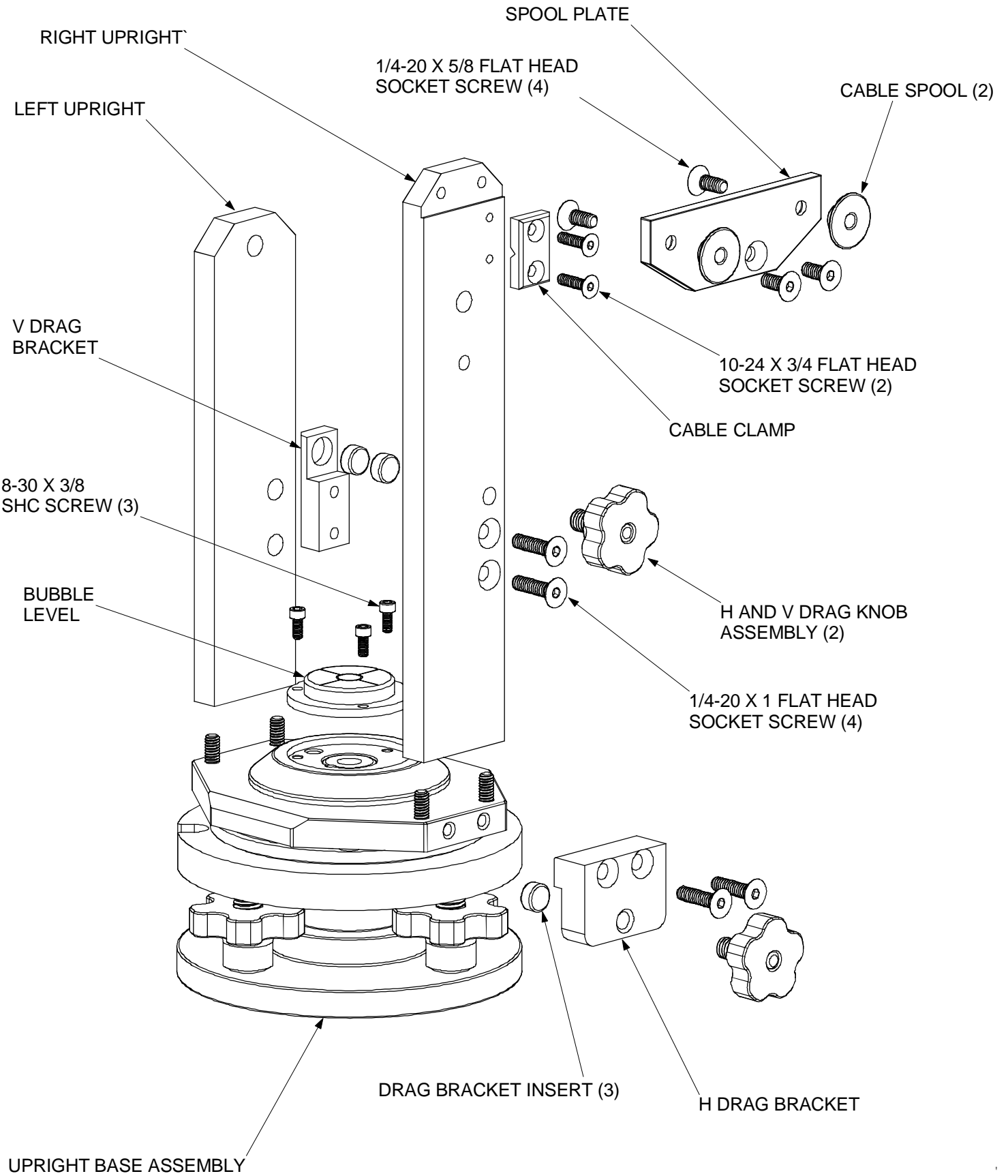

FRONT ASSEMBLY PARTS

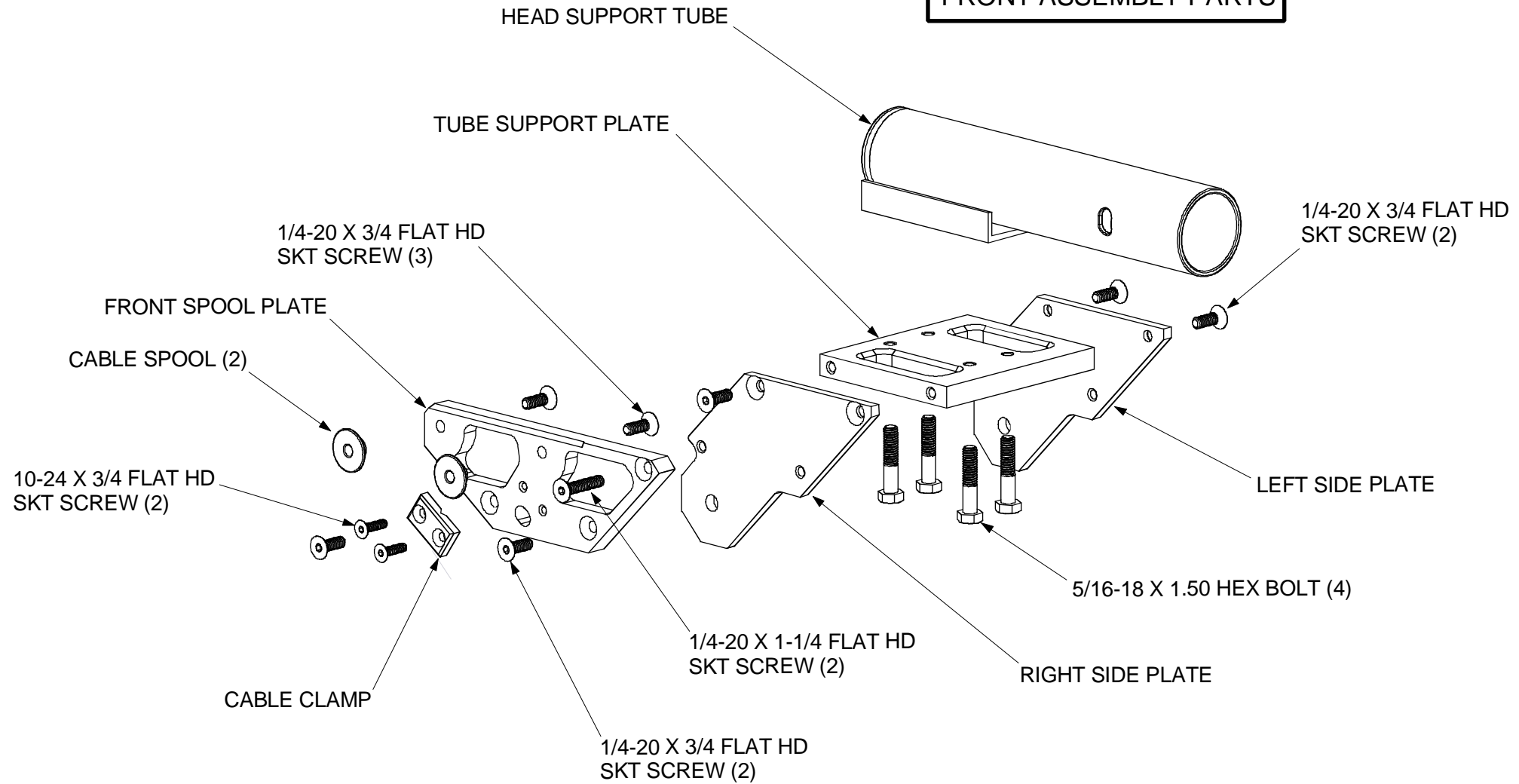

JIBE LITE PRO V-STRUT

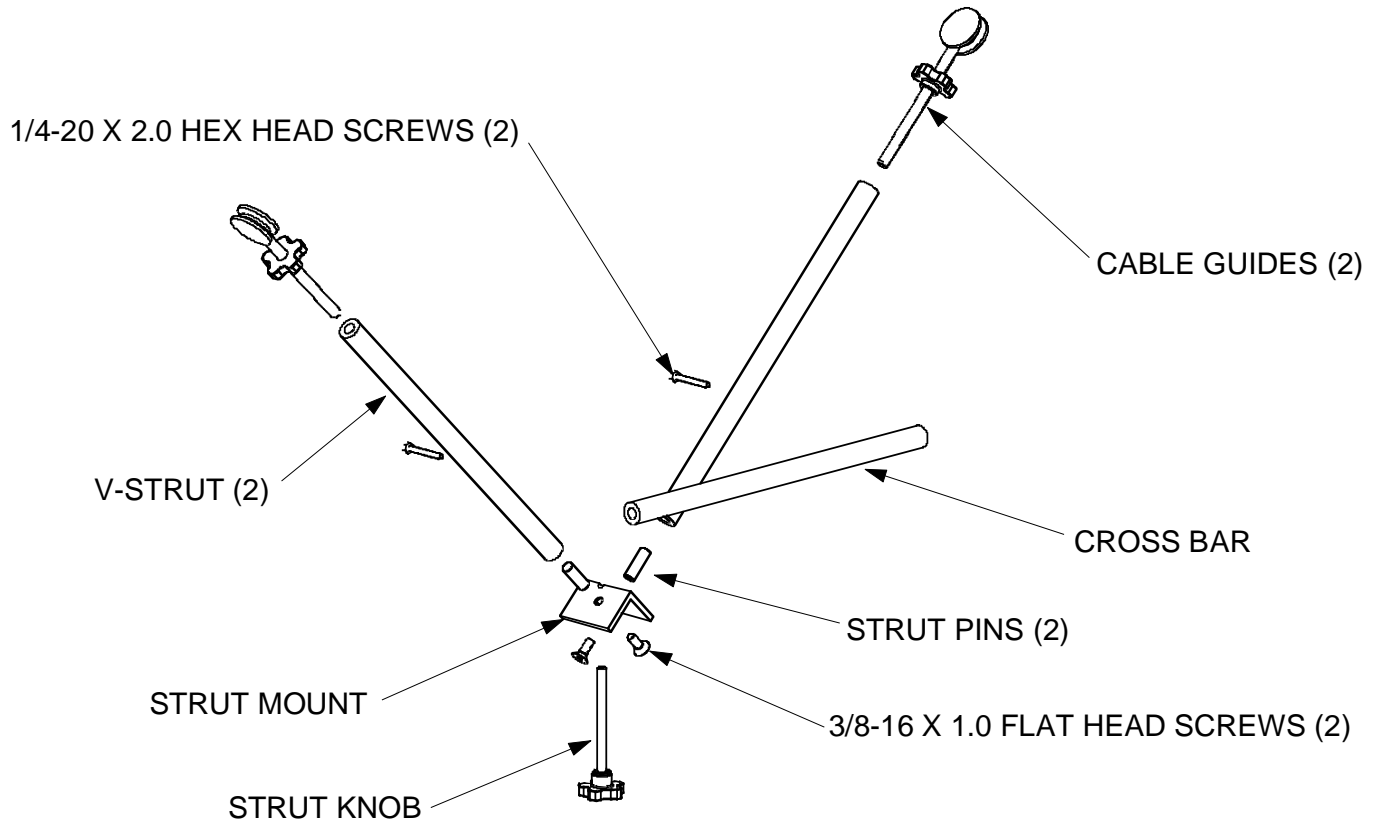

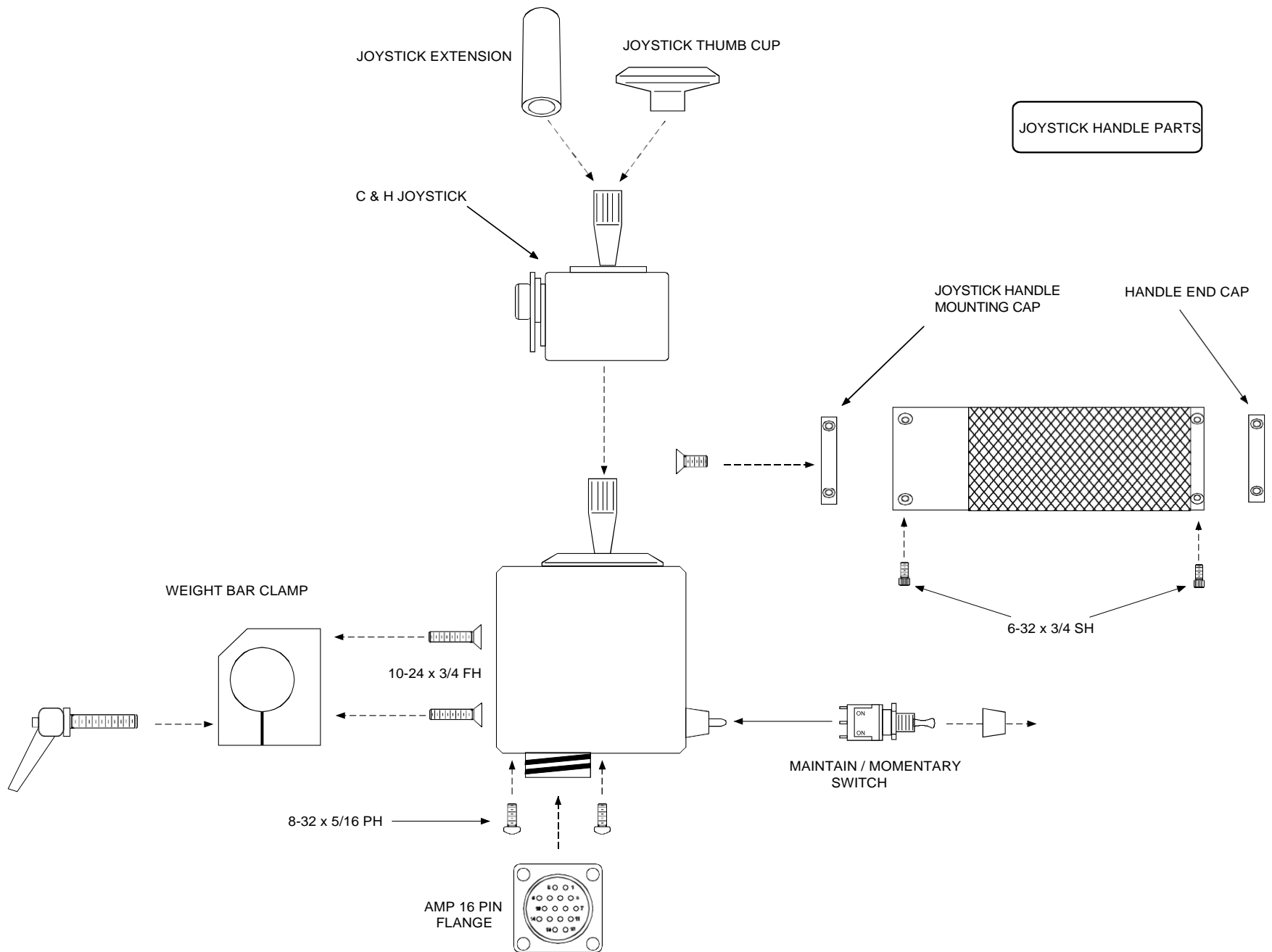

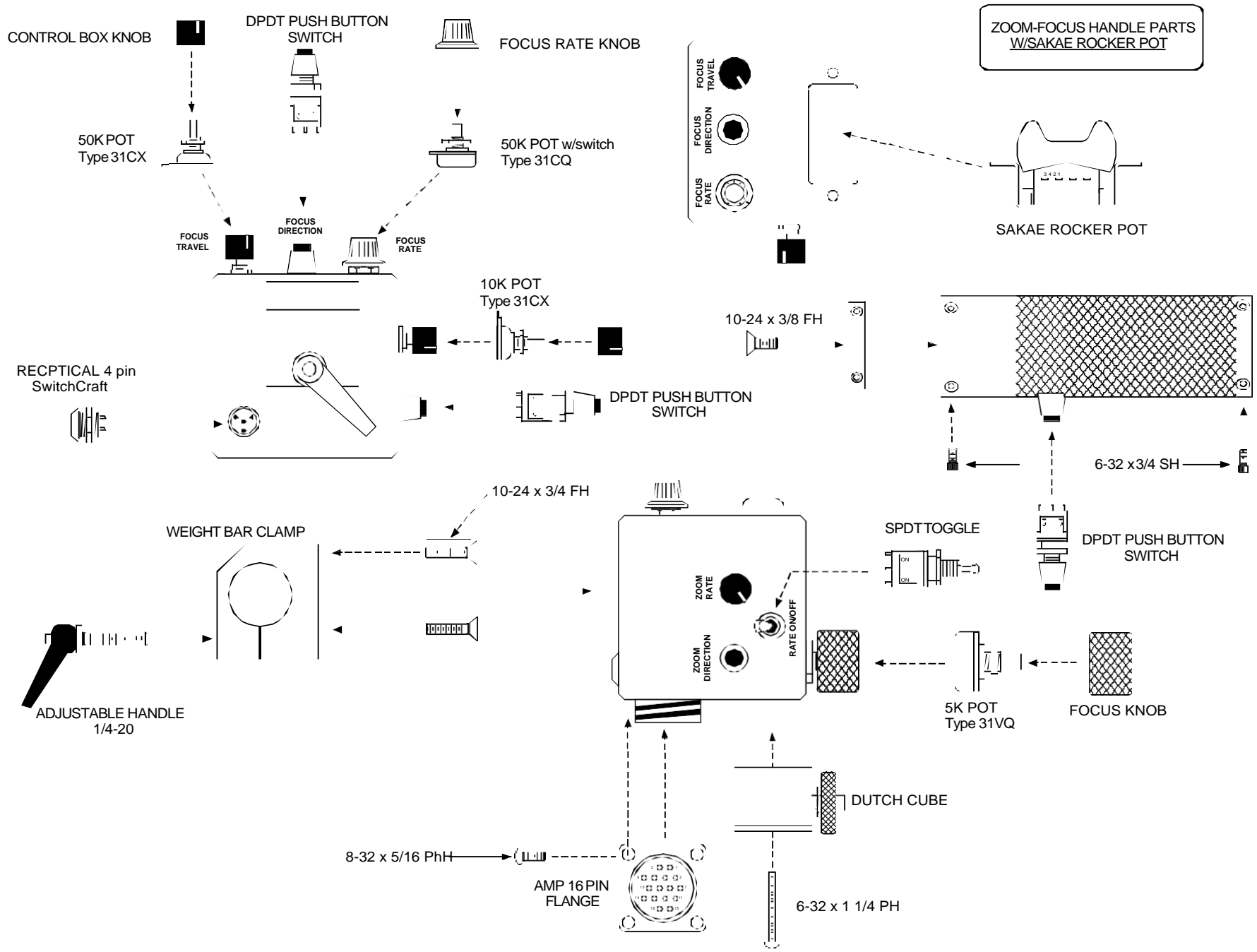

CONTROL PC BOARD

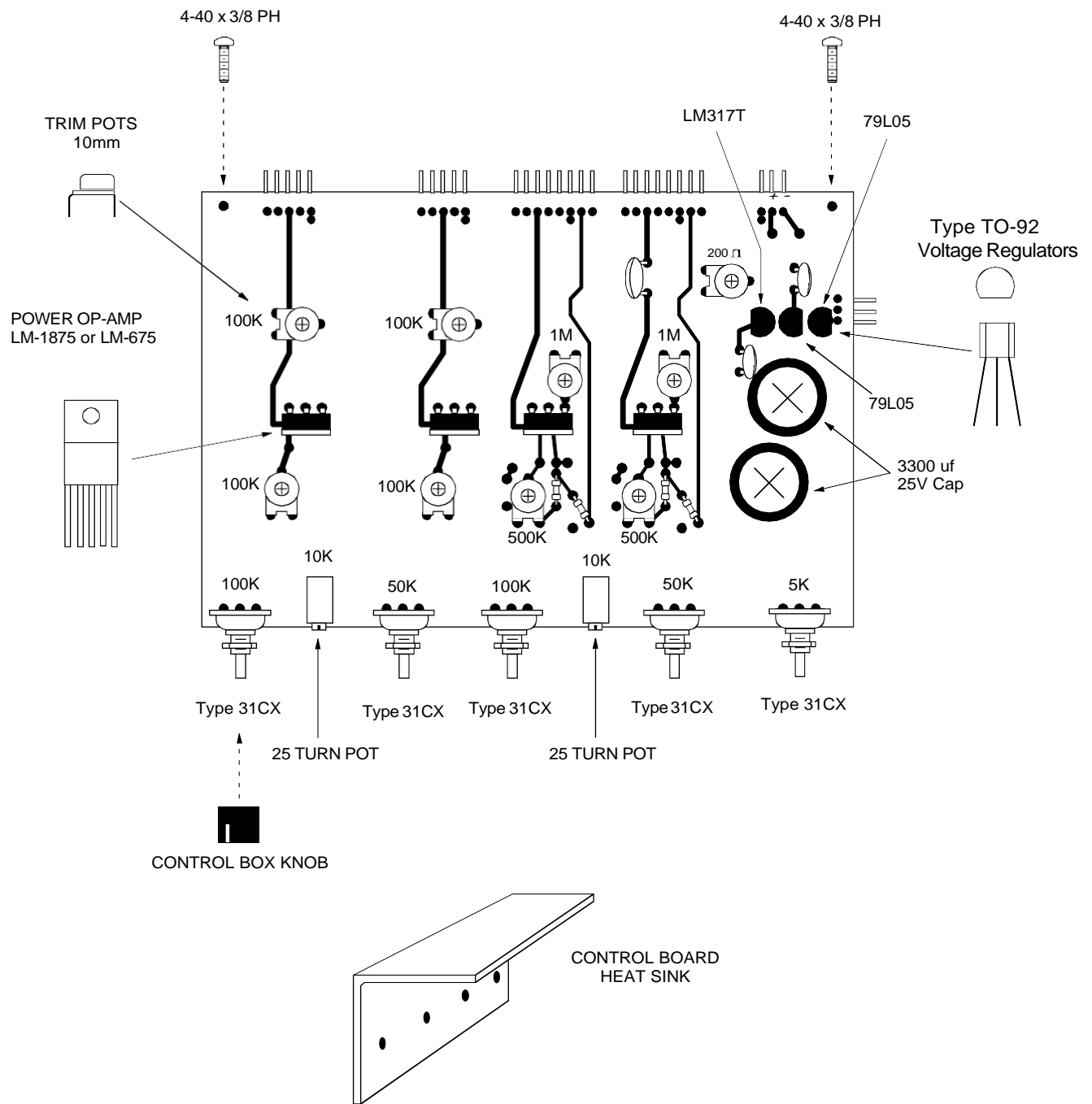

BATTERY BOX PC BOARD

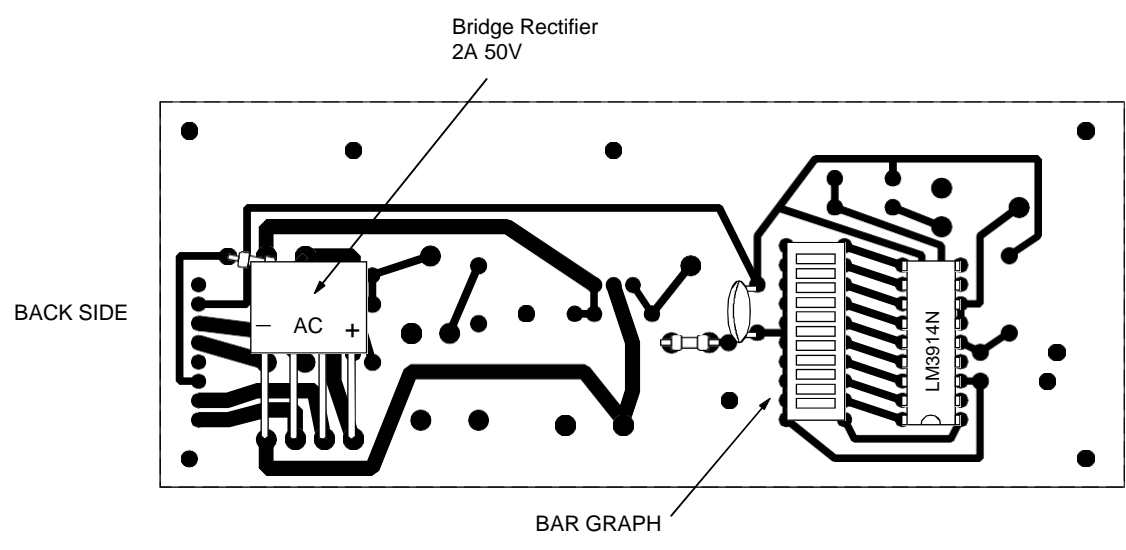
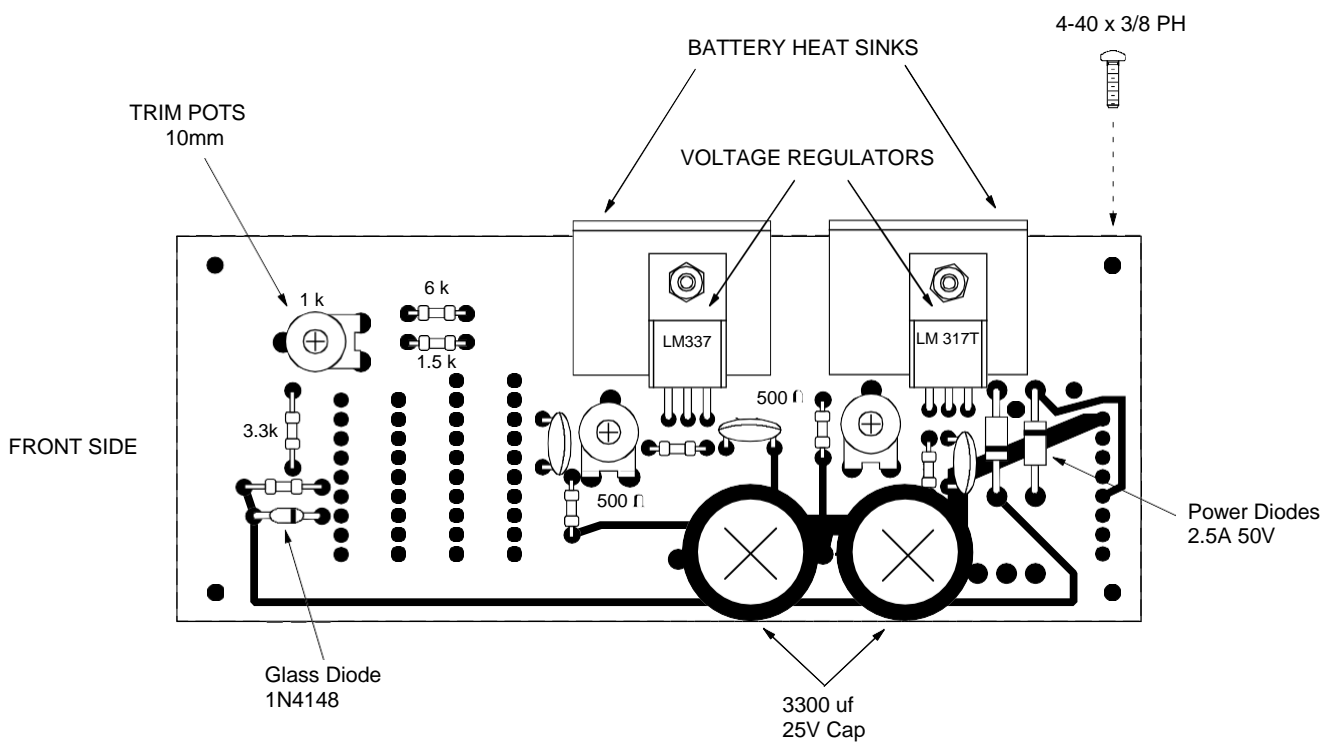

CONTROL BOX
BATTERY BOX
PARTS

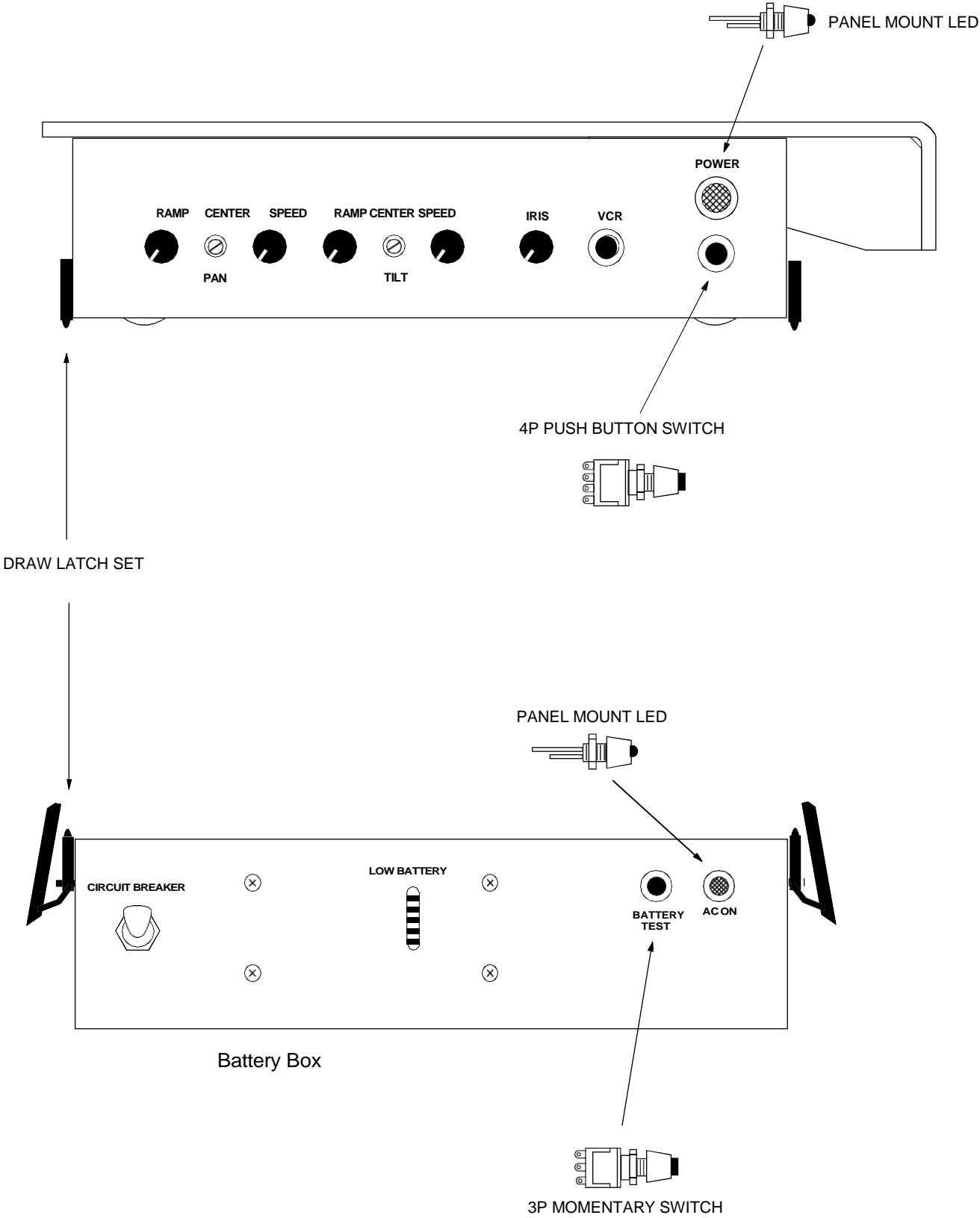

STANTON VIDEO SERVICES, INC.

2223 E. ROSE GARDEN LOOP
PHOENIX, ARIZONA 85024
602-493-9505

EC DECLARATION OF CONFORMITY

We, Stanton Video Services, Inc., herewith declares, that the following equipment complies with the appropriate basic safety and health requirements of the EC Directive based on its design and type, as brought into circulation by us. In case of alteration of the equipment, not agreed upon by us, this declaration will lose its validity.

Equipment Description: Stanton Remote Head Kit System
Stanton Mini Remote Head Kit

Equipment Type: Model No. 4 (including 4A, 4B and 4C)

Applicable EC Directives: EMC Directive 89/336/EEC
Amendment 92/31/EEC

Applicable Harmonized Standards:

EN 55022, Class B Limits and methods of measurements of Radio interference characteristics of information technology equipment.

EN 50082-1 EMC generic immunity standard Part 1: Residential, Commercial, Light Industry. IEC 801-2, IEC 801-3, IEC 801-4

Applicable National Technical Standards and Specifications: None Applicable

Notified Body: None Applicable

The CE Marking has been affixed on the equipment according to Article 10 of the EC Directive 89/336/EC.

Dated this 15th day of October, 2004.

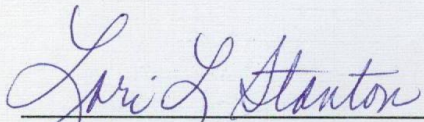

Lori L. Stanton, Secretary/Treasurer of
Stanton Video Services Inc.