

**JIMMYJIB TRIANGLE
PRO STANDARD**

Jan 22

If you are missing any of the following items, please contact Stanton Video immediately.
Phone: 602 493-9505 email: sales@jimmyjib.com

1. Front Tube
2. Center Section
3. Rear Tube
4. Pulley Cable
5. Weight Bar
6. Head Assembly
7. Camera Knob
8. 3/8 Ratchet with 1-1/2 Extension
9. Expansion Joint Handle

Maximum Camera Wt. 60 lbs (27.2 kg)

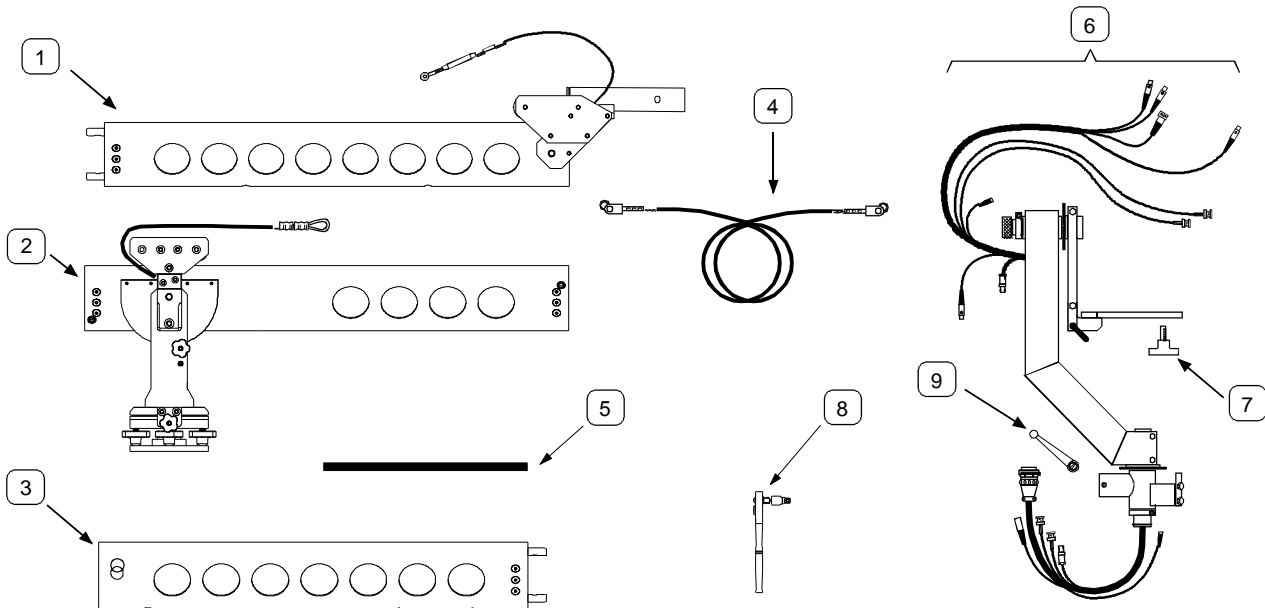

JIB ASSEMBLY

NEVER USE THE TRIPOD ON A SMOOTH SURFACE WITHOUT THE DOLLY. DOING SO WILL PUT SIDE STRESS ON THE LEGS & CASTINGS, POSSIBLY CAUSING A TRIPOD FAILURE.

1. **Prior to attaching any tube section mating surfaces must be clean and free of any debris.**
2. Remove the Center Tube Section and mount it to your Tripod. Level the Tripod using the level on the Pedestal Mount. Make sure the **Tripod Legs** and **Safety Clamps** are tight.
3. **Align a Tripod Leg with the Jib Tubes as you are assembling the Jib. This will prevent the jib from tipping during the assembly process.**
4. Attach the Rear Tube Section and secure it by locking the 3 cams using the ratchet provided.
6. Insert the Front Tube Section into the Center Section and lock the 3 cams.

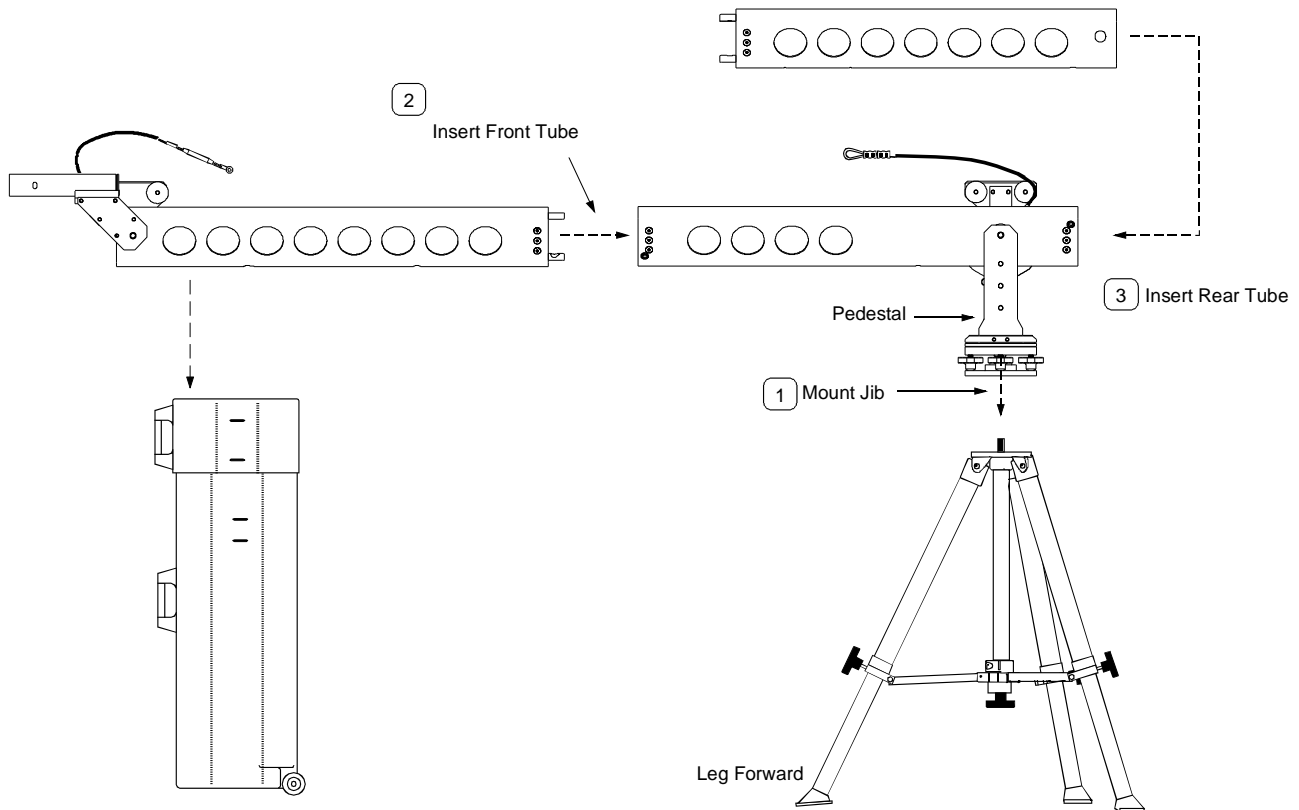

CAM LOCK CONNECTIONS

Torque to approx 30 ft lbs
(Always lock top cam first)

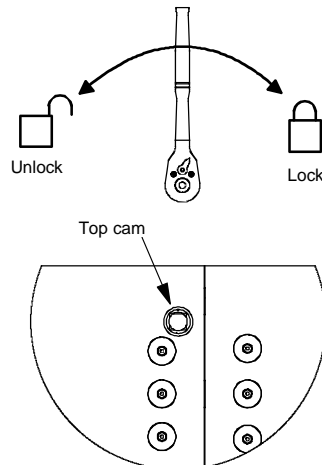

PULLEY CABLE

A steel wire rope cable (Pulley Cable) runs between the Pedestal and Front Assembly. This cable keeps the camera head level no matter what position the Jib arm is in. This is a good time to inspect the cable for breaks and frays. If any are found, the cable must be replaced.

1. Remove the Safety Ring and Pin from the Toggle Jaw.
2. Attach the Toggle Jaws to the wire rope and turnbuckle eyes. Make sure you insert the Safety Ring into the Pin.

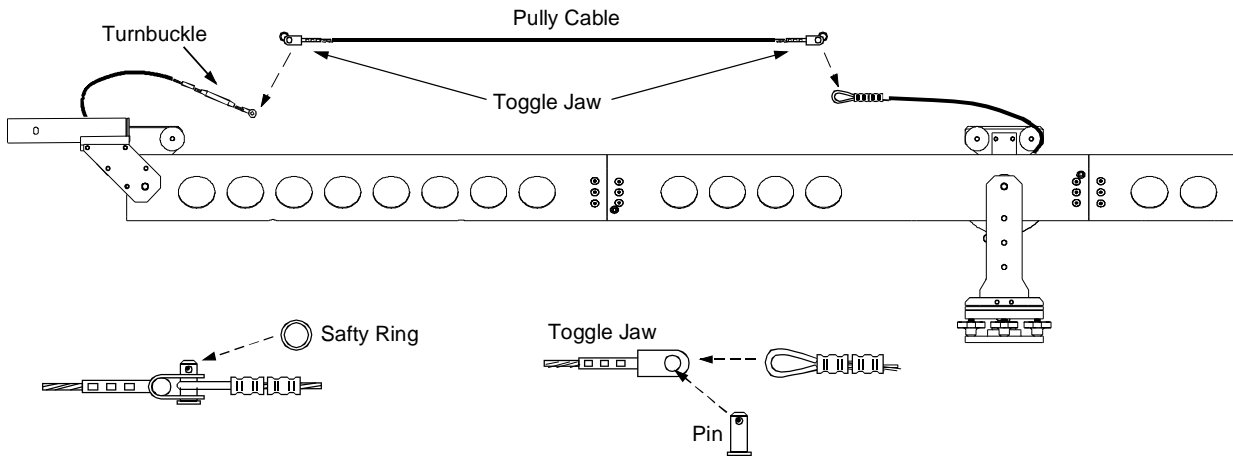

3. The Pulley Cable must be properly aligned with the Cable Spools.

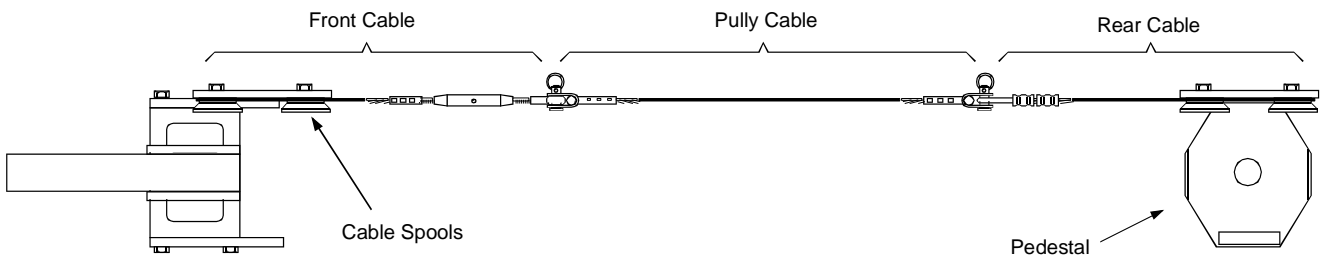

4. Install the weight bar through the holes of the rear tube.

MOUNTING THE HEAD

1. Support the front of the jib using the hard case or Pro Transport Dolly.
2. Remove the Expansion Joint Handle from the Expansion Joint and insert the Joint into the Head Support Tube.
3. Re-install the handle through the slot in the Support Tube and tighten.
4. After the Head is securely attached to the front of the Jib, **add some counter weight (25lb)** to the weight bar.
5. Level the Head Support Tube using the Turnbuckle. This may have to be redone after the camera is mounted.

Note: Lifting up on the head will relieve tension on the turnbuckle and make it easier to adjust.

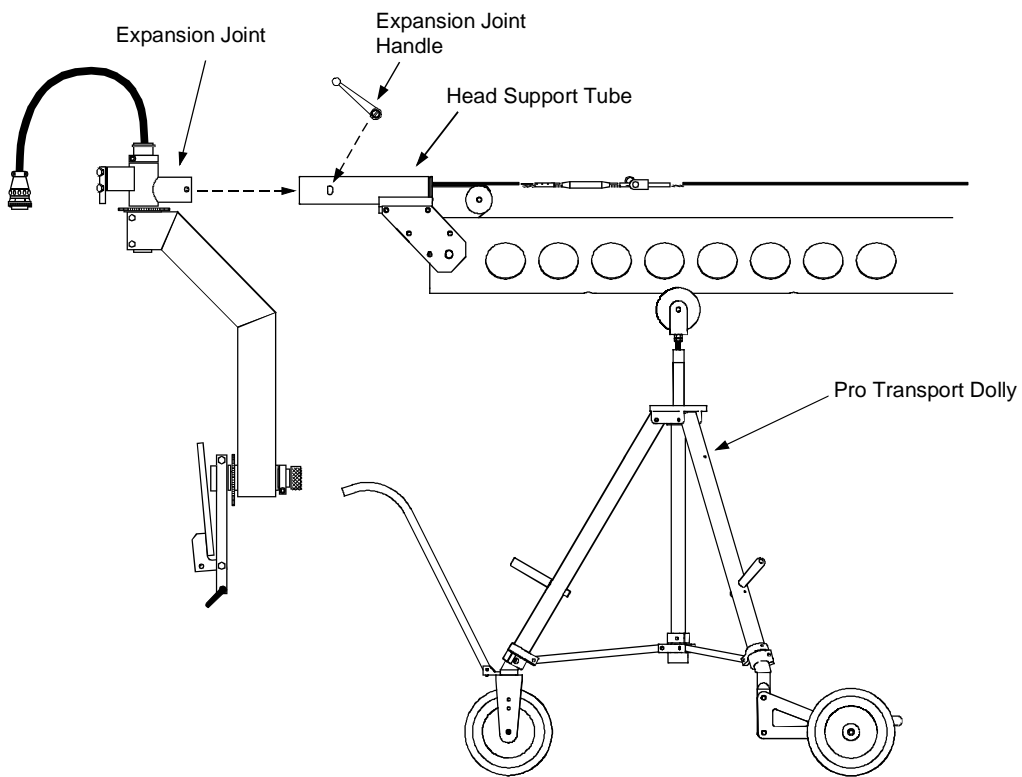

6. The Head can be leveled Sideways by loosening the Locking Screw and rotating the head to a vertical position.

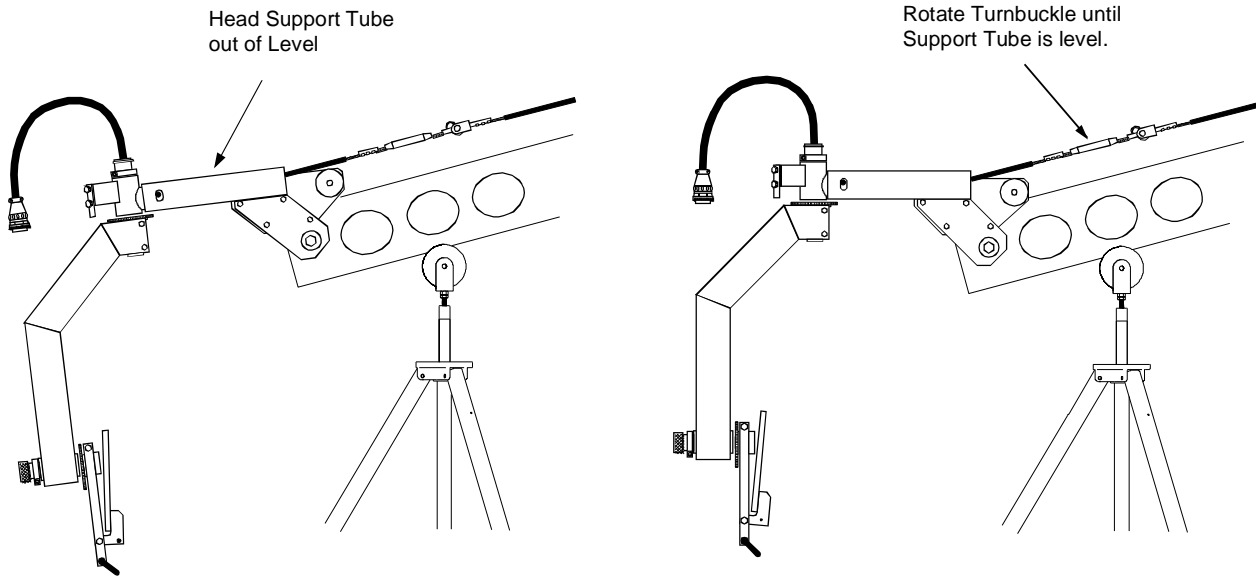

7. Remove the Camera Platform Handle and fold down the Platform. Insert the Platform Handle and tighten.

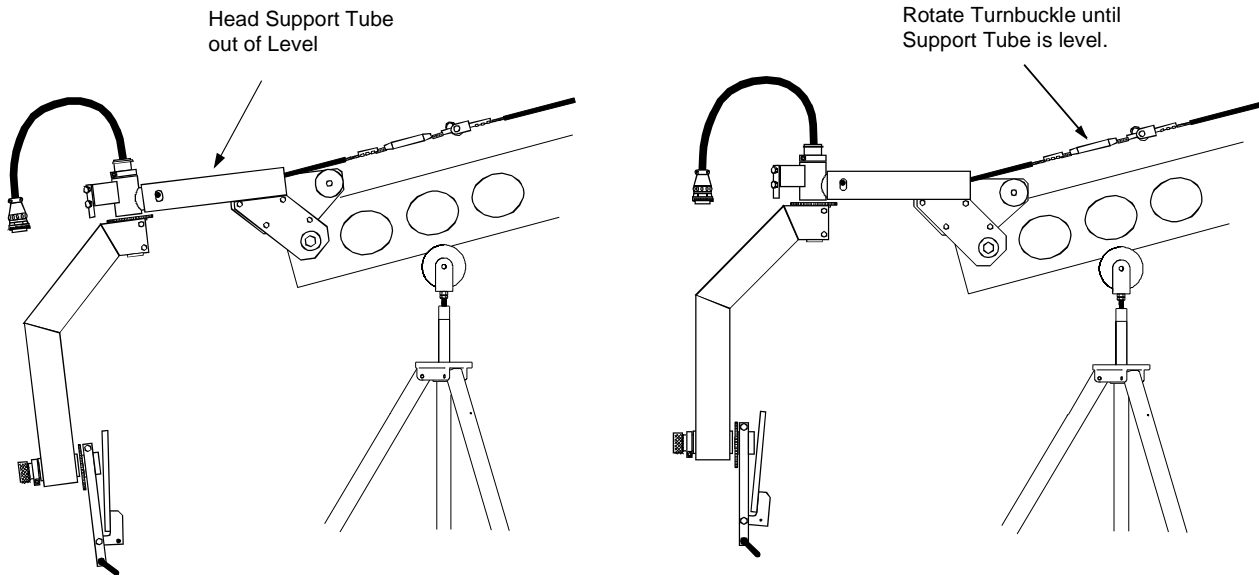

MOUNTING AND BALANCING THE CAMERA

NOTE: **Note: Always align a Tripod Leg with the Jib Tubes as you are assembling the jib. This will prevent the Jib from tipping during the assembly process. Before mounting the camera, add at least 25lbs of counter weight. During the mounting procedure, you must keep your hands on the camera at all times.**

1. Loosen the Swing Arm Knob and slide the Camera Platform to its lowest position and tighten. Mount the camera and secure in place with the Camera Knob.
2. Configure your camera completely with battery, quick plate, focus system etc. Mount the camera to the camera platform with the Camera Knob.
3. Slide the camera forward or backward in the platform slot until the camera stays level. Tighten the Camera Knob.

NOTE: You cannot leave the camera in this low position. If you do the camera will act like a pendulum and always try to swing to this low position.

4. Loosen Swing Arm Knob. Slide the Swing Arm and Camera up in 1/2 in. increments. The tendency of the camera to pendulum back to center will become less as the Swing Arm moves up.

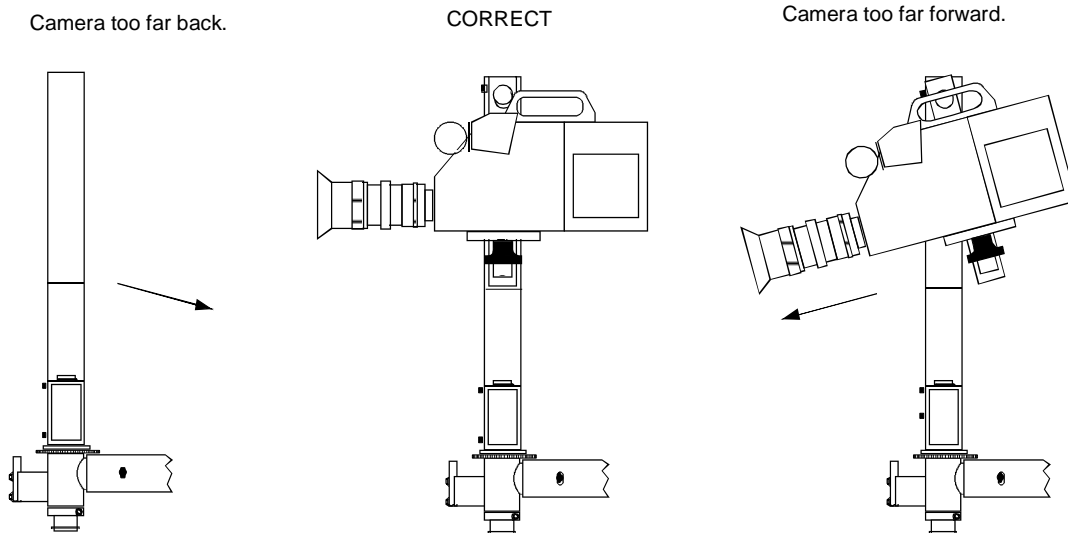

5. When you reach the vertical balance point you will be able to rotate the camera to any position and it will remain in that position.
6. If you move the camera too high on the Swing Arm, it will try to rotate upside down.

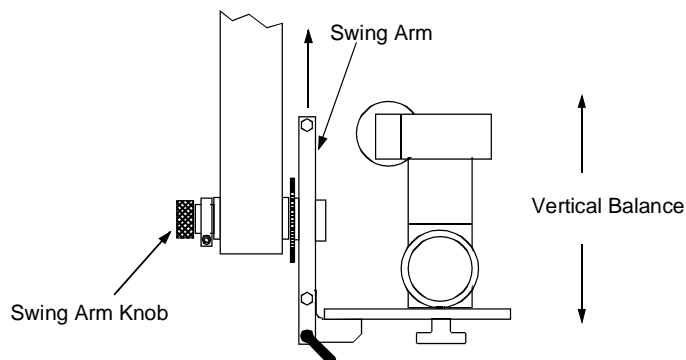

JIB BALANCING

1. Make sure all securing knobs for the camera, Camera Platform, Jib mount and Tripod Legs are tight.
2. Use standard barbell weights (1 in. hole size). Olympic style weights are not recommended because the center hole is too large, causing the weights to be suspended below the Jib centerline.

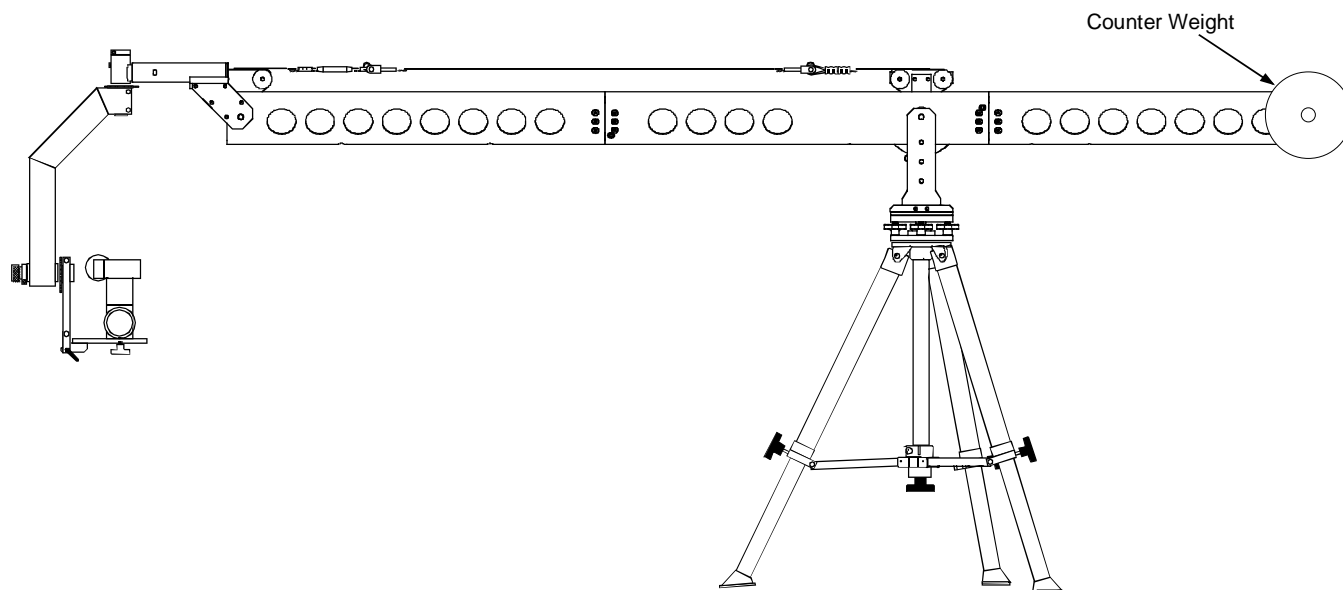

3. Start by loading 25 lb. plates on the weight bar, stacking them equally on both sides of the Rear Tube Section. Switch to lighter weights as the Jib becomes more balanced. When you get to within about 5 lbs. of the balance point, you may wish to fine tune the Jib with the optional sliding Ballast Bag.

NOTE: When using the Ballast Bag, make sure the bag sits on top of the tube, not slung underneath. Bottom mounting will cause the Jib to return, on its own, to a level position.

OVER SLINGING THE HEAD

The Head can be mounted in the upright or over slung position. The camera will be more stable however, if the Head is under slung. Also keep in mind that it is possible to tip the Head and camera over, as only the weight of the Head and camera holds the head level. Under normal operation, tipping the Head over is virtually impossible. However, if the Jib is armed down against an obstacle and the operator continues to push hard enough, tipping is possible.

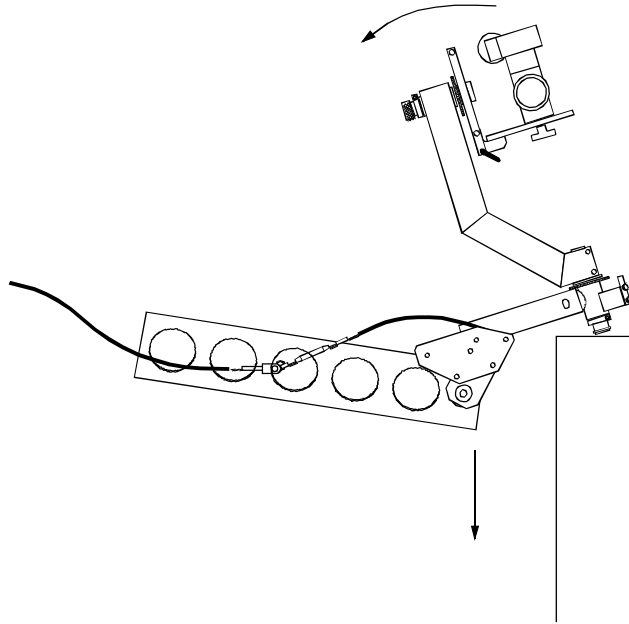

BREAKDOWN

1. The main thing to remember when taking down the Jib is to **Always remove the counter weight first.** If the camera is removed first you will have created a catapult, which if released, will topple the Jib over and ruin your day.
2. Make certain you align the Jib arm with a Tripod Leg before removing the counter weight. Failure to do this may cause the Jib to tip over. Leaving about 25lbs of counter weight on the Jib will help alleviate this possibility.

MAINTENANCE

1. Inspect the Pulley Cable, upon each set up, for any damage or wear and replace if necessary.
2. All threaded parts that are frequently unscrewed should be lubricated; this is especially true of any aluminum threads. Motorcycle chain lube works well for this.

REMOTE HEAD KIT

If you are missing any of the following items, please contact Stanton Video immediately.
602 493-9505

1. Head Assembly
2. Control & Battery Box
3. Joystick Handle
4. Zoom/Focus Handle
5. Pan & Tilt Motors
6. HDV Extension Cable 20 ft (6.1m)
7. AC Transformer
8. Control Box Cable
9. Battery Cable
10. Control Cable
11. Follow Focus

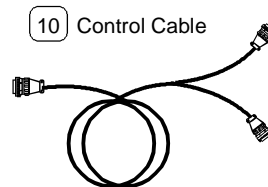
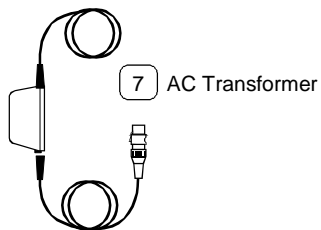
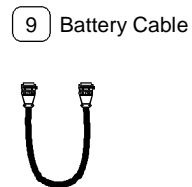
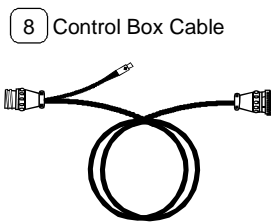
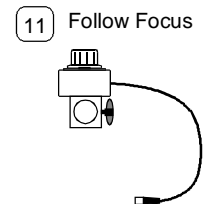
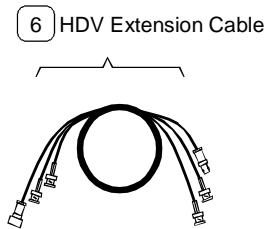
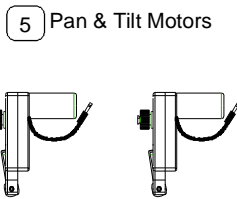
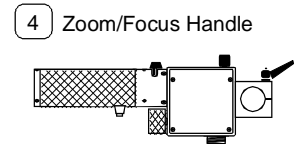
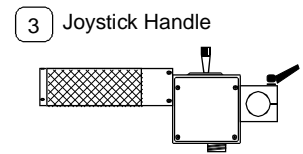
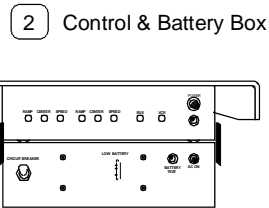
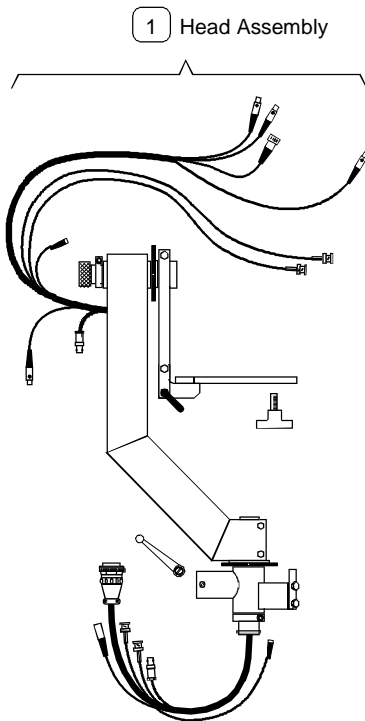

CONNECTORS

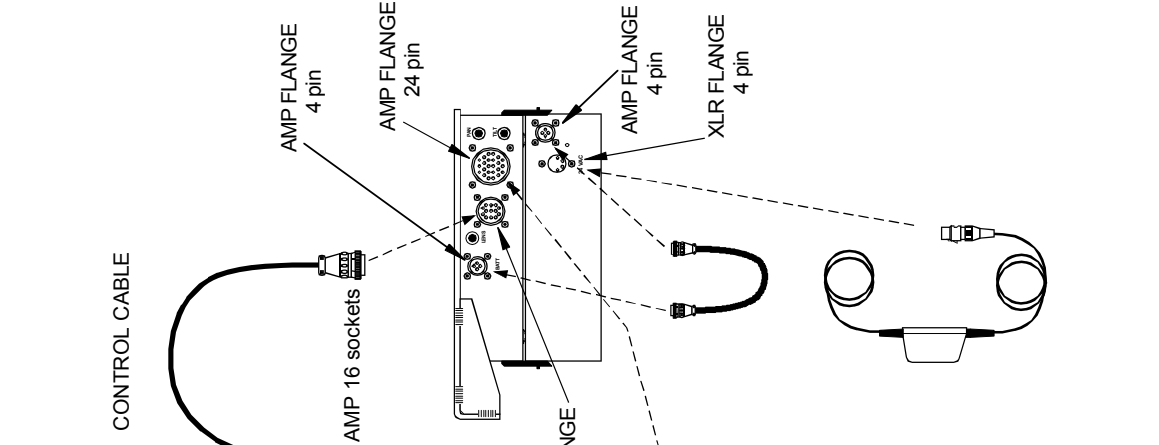
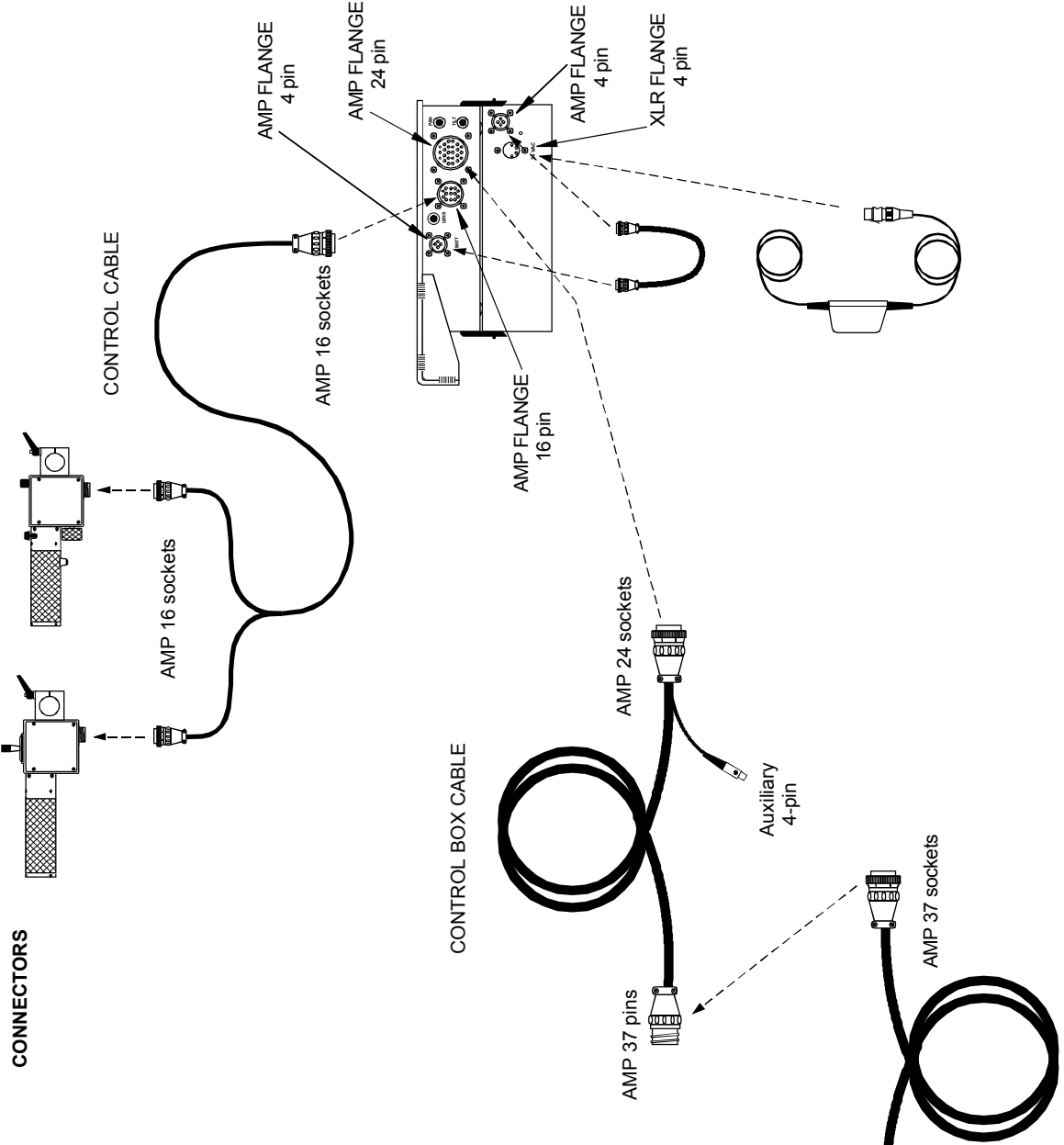
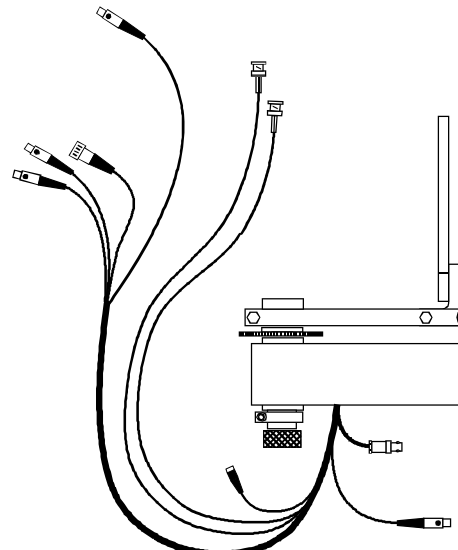

PAN & TILT MOTORS

1. The camera should be mounted and balanced before engaging the motors.
2. The Pan and Tilt Motors are mounted to the head through the use of a pin and a pinch type motor mount bracket. The Pins are attached with a Spacer Block and screws.
3. Engage the motors by rotating them into the 4 in. gear and tightening the pinch clamp.

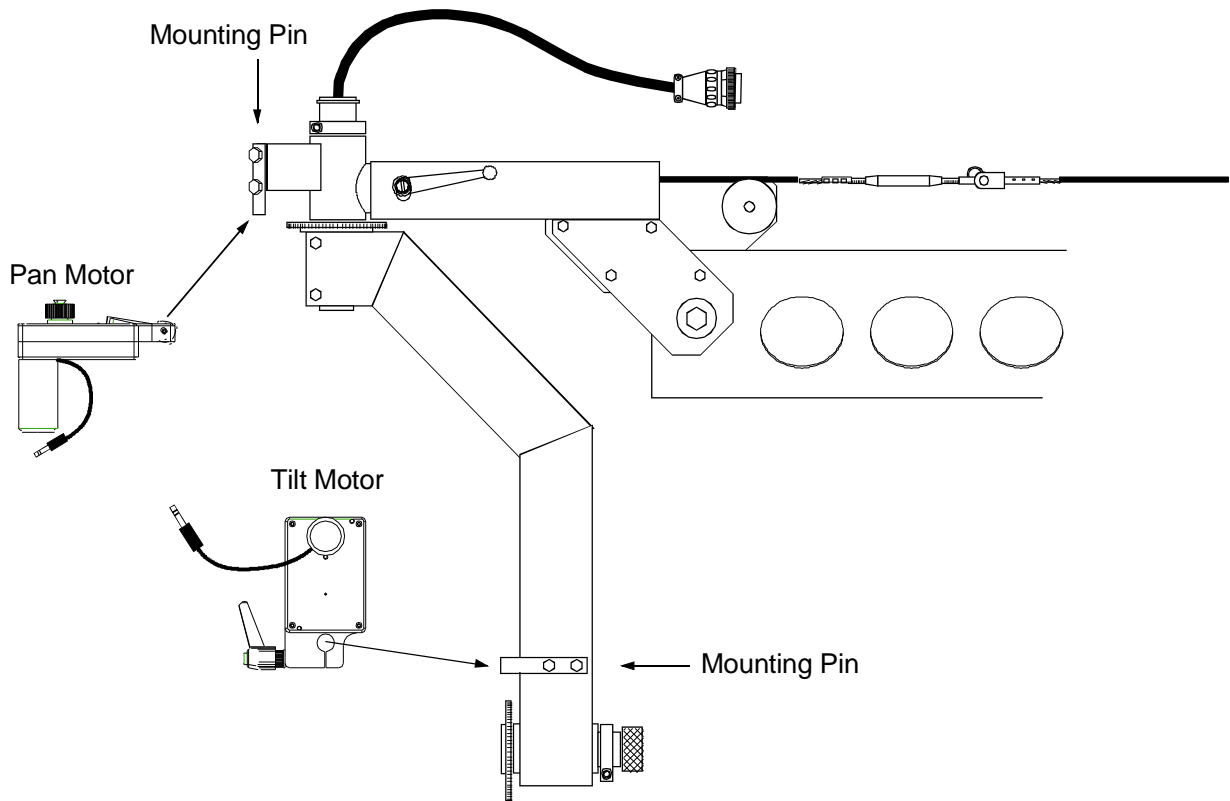

PAN & TILT SLIP CLUTCH

NOTE: The most common mistake made by first time jib users is the improper balancing of the camera. If the camera is out of balance, the strain on the Tilt Motor will cause the motor clutches to slip. This is a safety feature. The Clutches prevent damage to the gear motor when inverting or moving the Head manually with the motors engaged.

The clutch friction should be high enough to allow the motors to pan or tilt the camera but still have enough slippage to allow the head to be moved manually. If the clutches are slipping (during normal joystick operation) and you are sure you have balanced the camera properly, it may be necessary to increase clutch tension. The clutch adjustment screw is locked with a set screw which prevents the screw from turning when the gear slips. To increase friction loosen the Set Screw and then turn the Clutch Screw clockwise a small amount. Make sure to tighten the Set Screw to lock the adjustment in place.

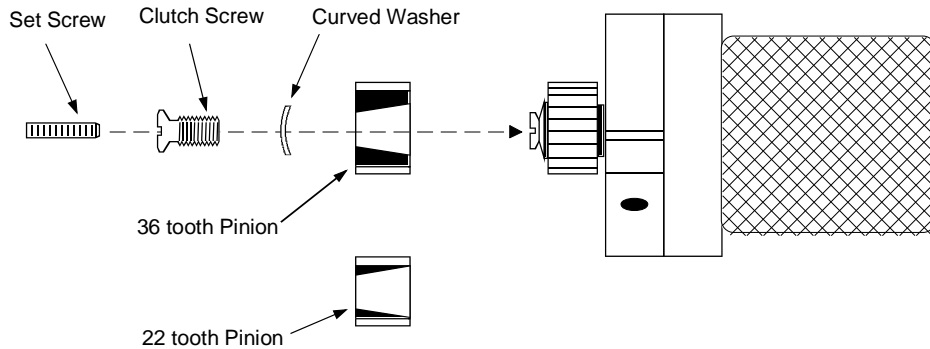

It has been found that the use of the small 22 tooth pinion on the Tilt Axis has improved the "feel" and movement of this Axis. This is especially true when using heavier film cameras. This small pinion is available as an accessory.

FOCUS & IRIS MOUNT

The Focus/Iris assembly consists of two servos with gear wheels attached. This assembly mounts to the screw hole utilized by the lens manufacturer to mount their cable drive focus systems. As you tighten the Lens Mount Knob to mount the assembly, you must be careful that the screw does not bottom out inside the lens. If you continue to force the screw you may do internal damage to your lens.

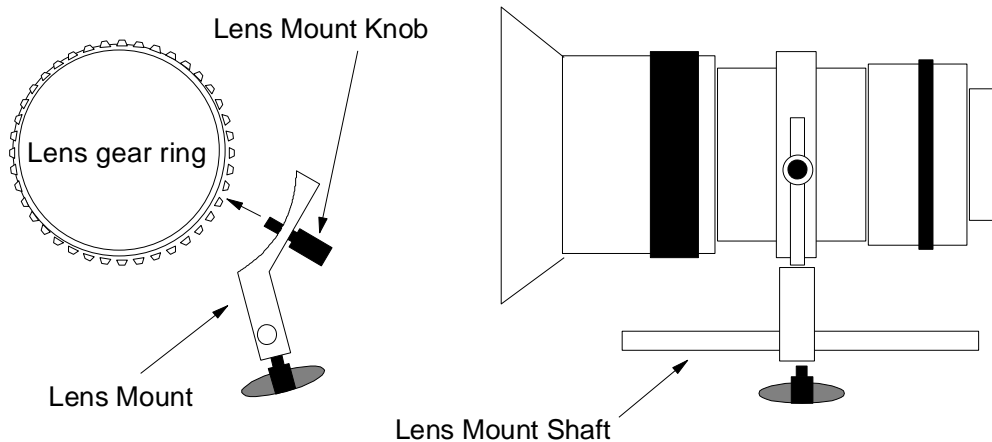

Occasionally the curvature of this mount is greater than the lens curvature. This means that there will be contact only at the center of the mount instead of along the entire curve. This can cause the Focus/Iris assembly to twist on the lens. To correct this problem, adjust the set screw in the Lens Mount. Back out this set screw only far enough to just touch the lens.

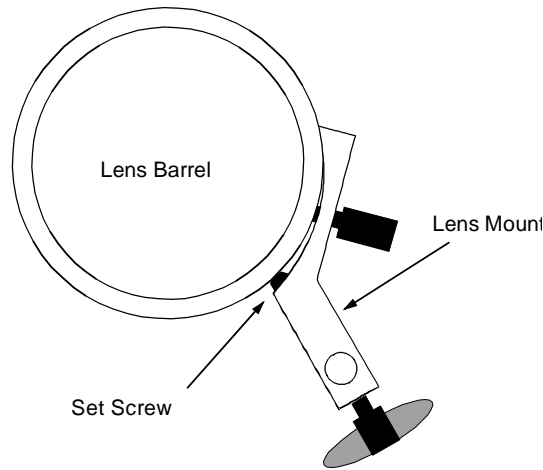

IRIS SERVO

1. The lens auto iris switch should be in the off position.
2. Slide the Iris Servo onto the Lens Mount Shaft and plug the servo into the proper (blue) connector. **Turn the unit on.**
3. Rotate the Lens Iris clockwise (iris closed) until you hit the lens stop. Rotate the Iris Servo gear (using the Iris Knob on the control box) counter clockwise until you hit the servo stop. This will synchronize the Lens and Servo stops.
4. Engage the Iris Servo with the Lens by rotating the Iris Servo on the Lens Mount Shaft. Lenses with extenders may require the Iris Servo to be reversed in its mount.

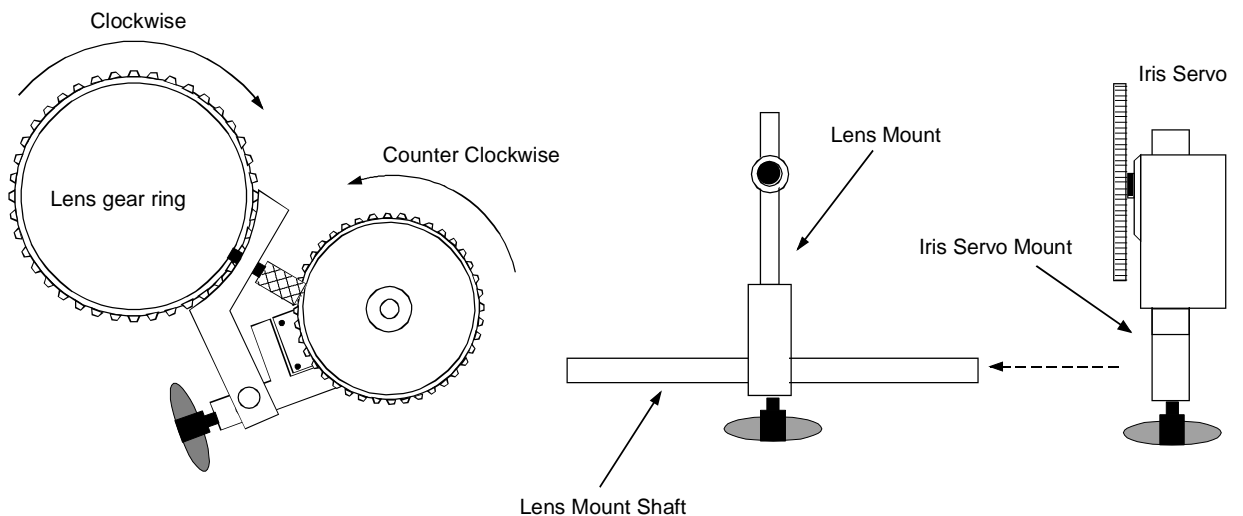

FOCUS SERVO

1. Slide the Focus Servo onto the Lens Mount Shaft and plug it into the proper (red) connector.
2. Rotate the Servo on the Shaft until the Lens Focus Gear ring and servo gear engage.
3. The Focus Servo Bracket is spring loaded. Compress this spring slightly when you engage the gears.

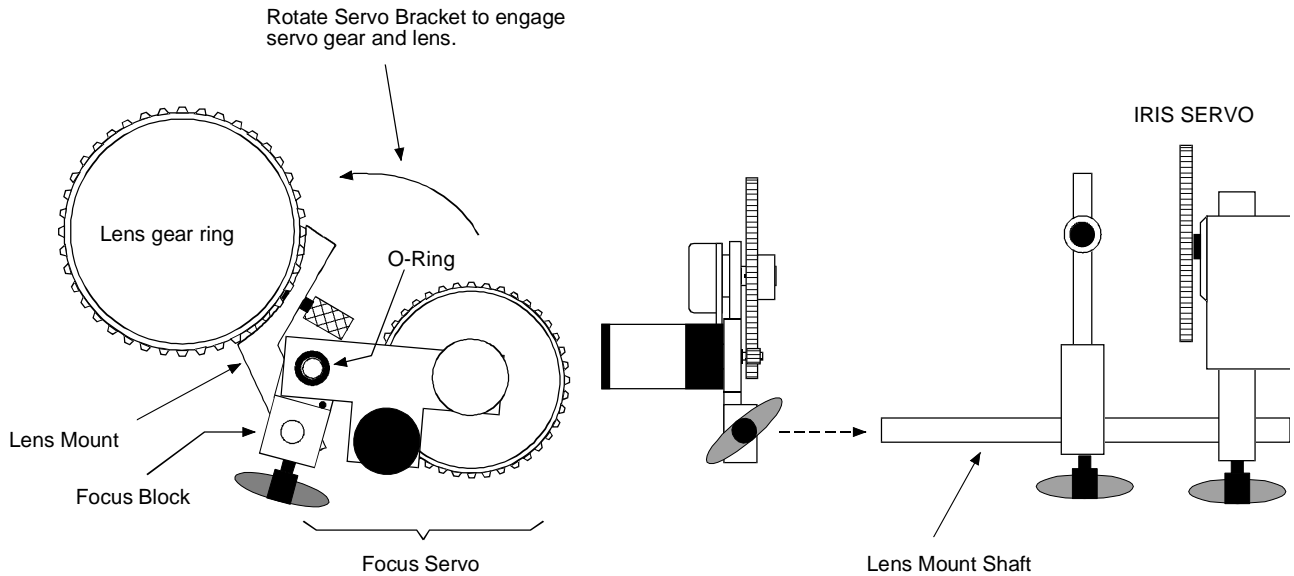

If you have a Canon Lens, the Master Gear will directly engage the lens. If you have another lens it will be necessary to add an extra gear. Slip the extra gear over the hub of the Master Gear and secure with the 4-40 screw.

The Focus Block can be placed in multiple positions to facilitate mounting the Focus Servo to a variety of video lenses and cameras. The o-ring holds the focus block in place. While inserting the focus block into its new location, the Spring Plunger must be depressed with a small screw driver.

The Focus Servo can be mounted to 15mm matte box rods by removing the Focus Block and replacing it with a 15mm Focus Block. This is an accessory available from Stanton Video.

Focus Rotation

Focus rotation is set at the factory at about 90°. This will usually be more than enough for most video lenses. If you need to increase focus rotation refer to the last page under PC Board Adjustments. You should call Stanton Video before making this adjustment.

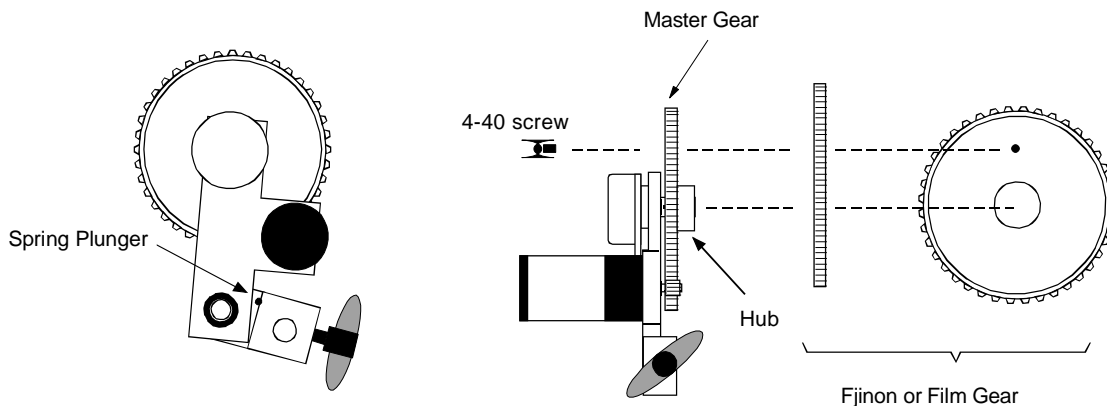

FOLLOW FOCUS SYSTEM

1. **Follow Focus Box:** The Follow Focus allows an assistant to pull focus when necessary. This is achieved by plugging the Follow Focus Box into the Zoom-Focus Handle.
4. **Set Point Switch:** This switches focus control from the Focus Knob on the bottom of the Handle, to the Follow Focus Box. This allows you to rack focus between two focus set points by using the follow focus as a memory position.
5. **Focus Rate:** Is used when switching between focus set points. This pot controls the elapsed time to perform the focus.

NOTE: The Set Point Switch transfers focus control back and forth between the Focus Handle and the Follow Focus Box. If the follow focus is not connected and the switch is in the wrong position the focus control on the handle will not work.

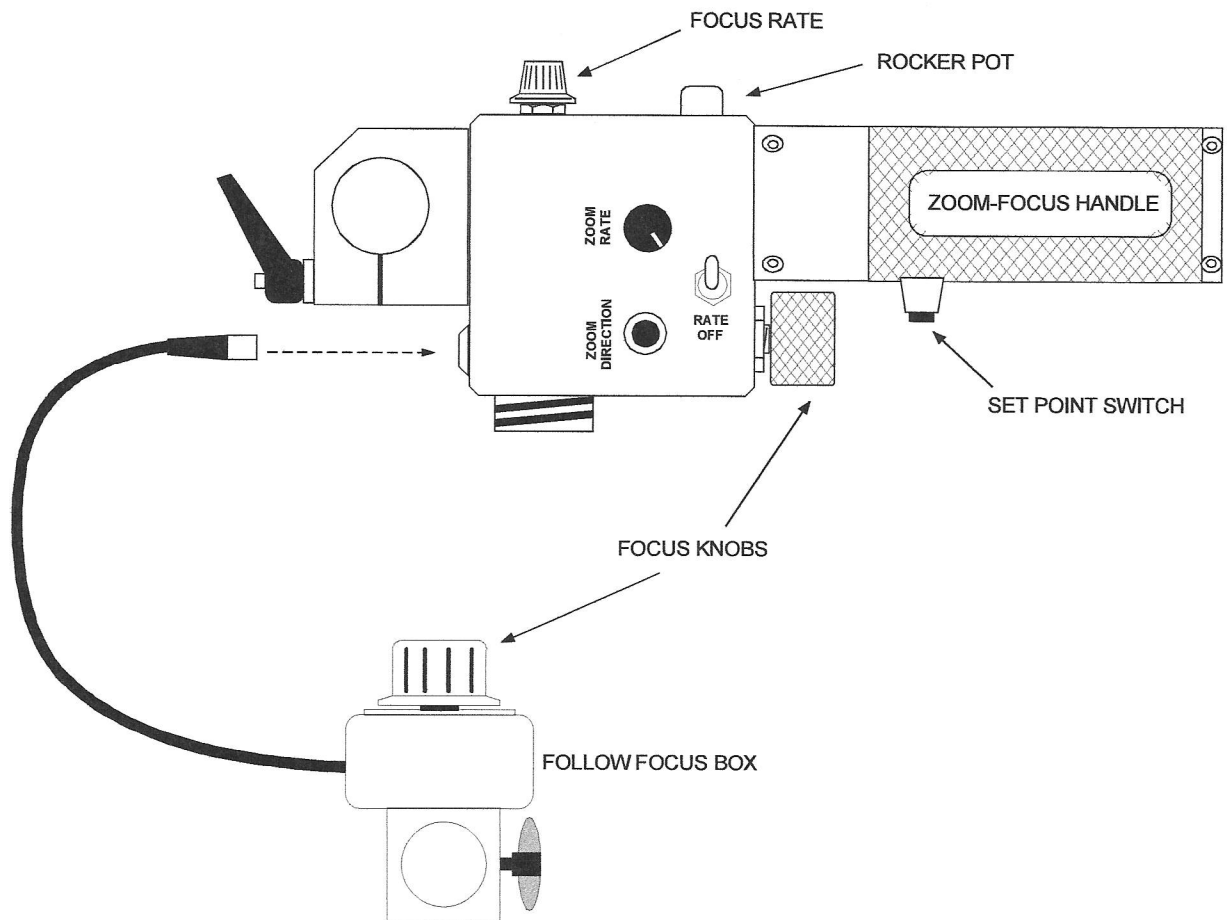

MODEL 4C ZOOM & FOCUS CONTROL

For Model 4B see following manual pages.

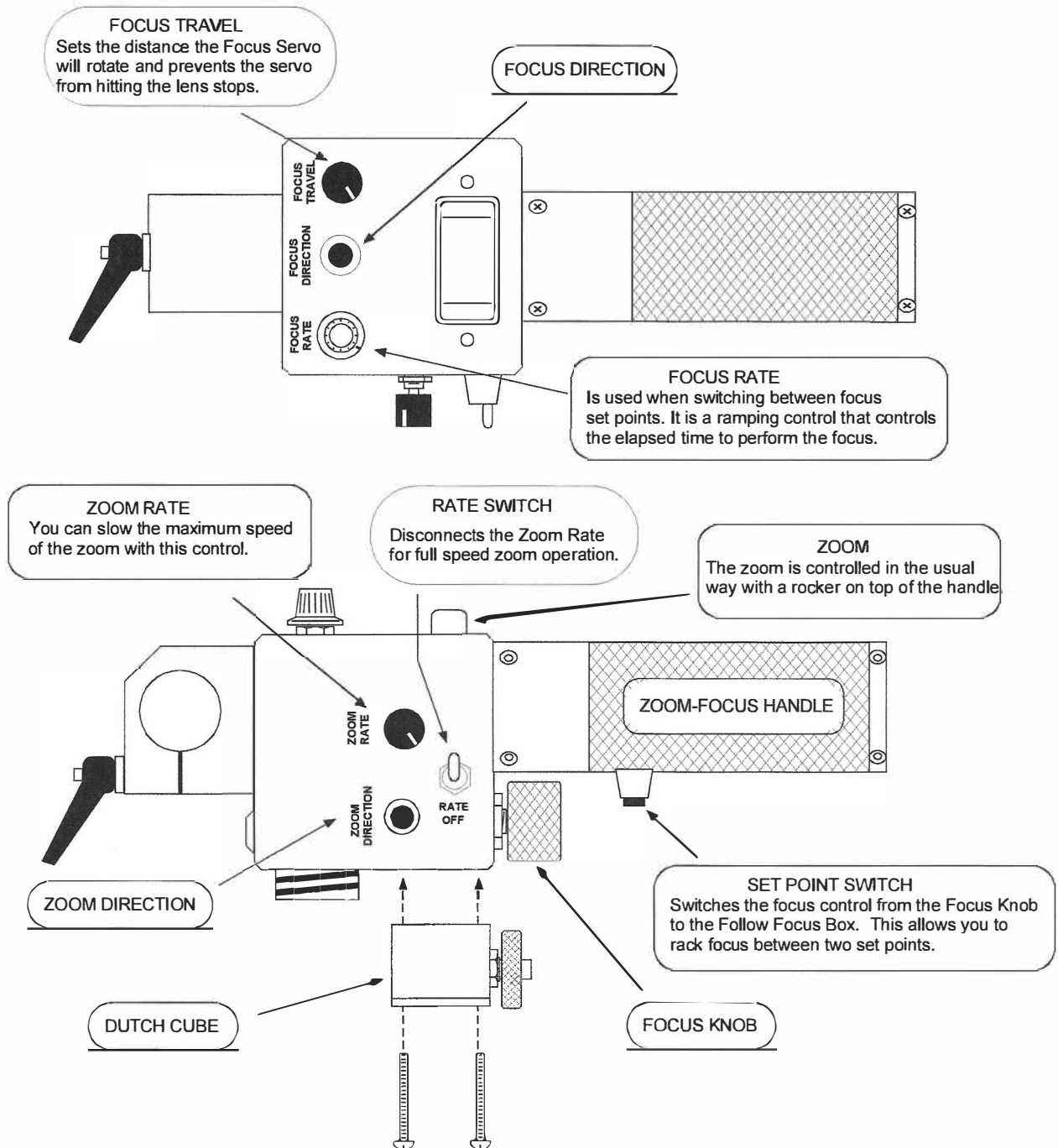

* To use the optional Dutch Cube, follow the instructions below:

1. Attach the cube to the zoom/focus handle (or the joystick) with the two attachment screws.
2. Plug the connector into the external jack on the Dutch Controller until the Cube is activated.
3. Cycle the selector button on the Dutch Controller until the Cube is activated.

Note: It is also possible to plug the Cube into the external jack on the Focus Handle and utilize it as an extra focus control.

Note: **For users with an older system upgrading to new controls:** The new control handles may be used with any Model 4 control box but you must purchase a new Control Cable and make a wiring change in the control box. After the wiring change, your old controls **will not be compatible**.

JOYSTICK HANDLE

You can change the joystick control from a thumb operated style to a more conventional setup with the Joystick extension. Remove the four attachment screws, take off the handle and then push on the longer extension.

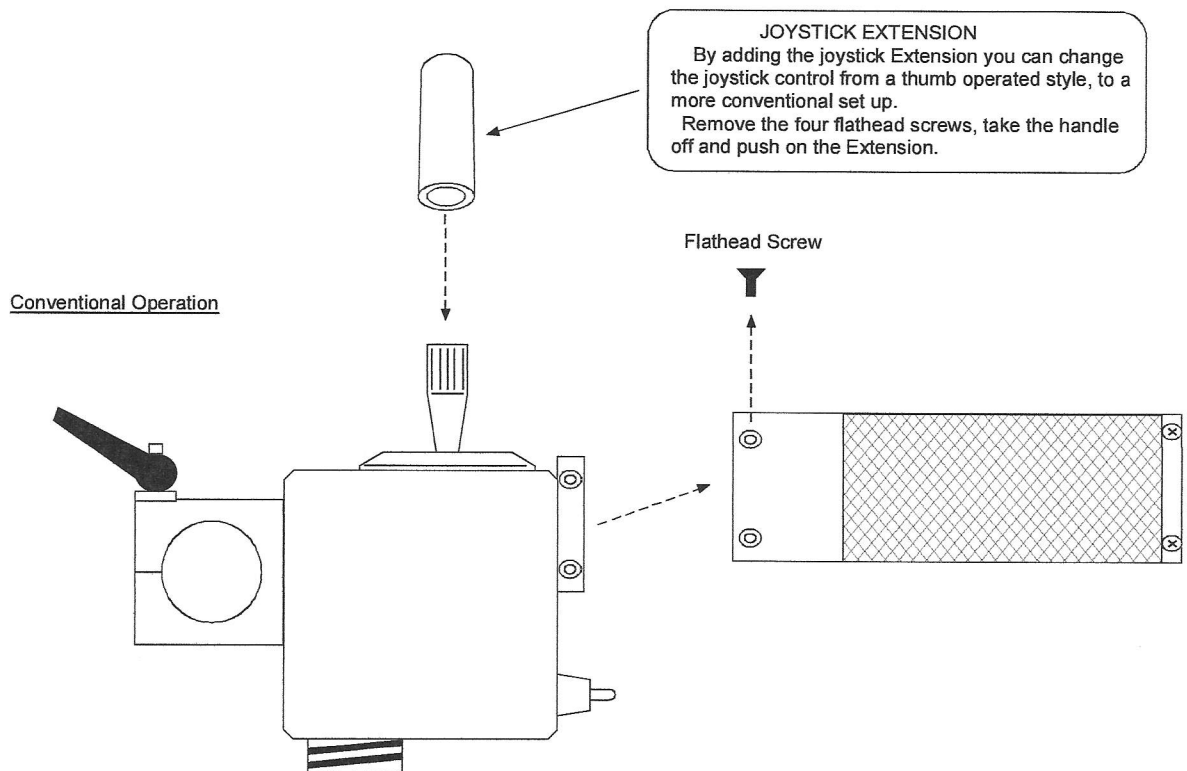
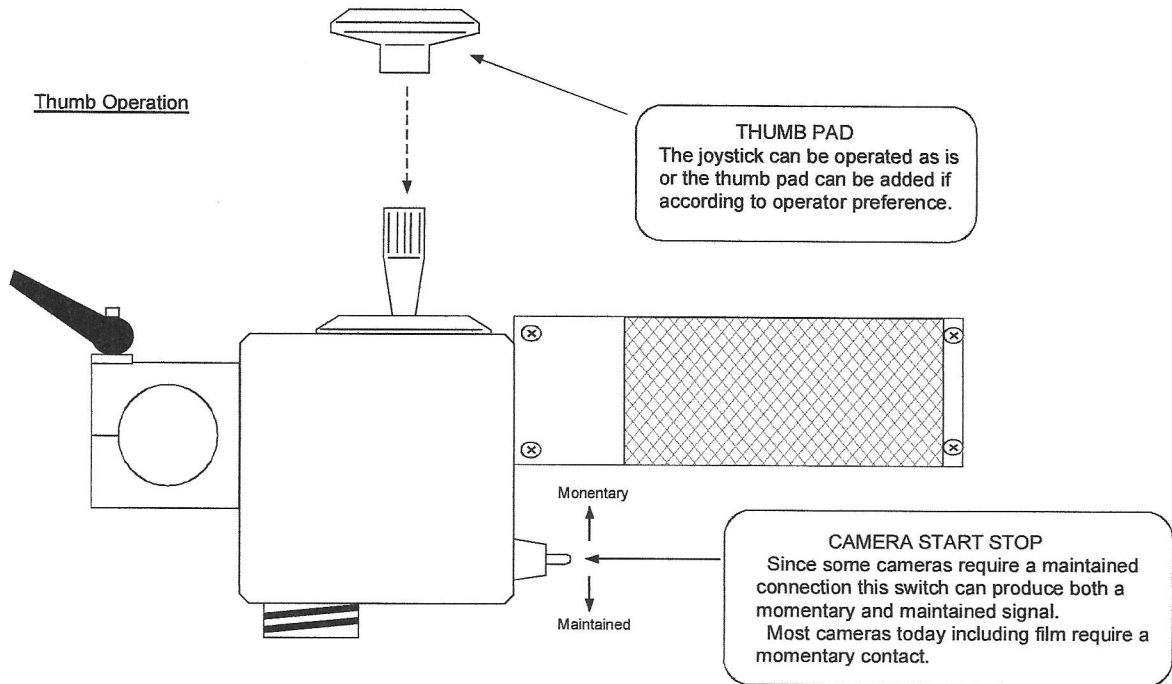

CONTROL & BATTERY BOX

1. The lid of the Control Box is also the monitor platform. The control box assembly is attached to the pedestal as shown below.
2. Attach the Battery Pack to the bottom of the Control Box. When the side latches engage, you will hear a snap if they have locked into position.

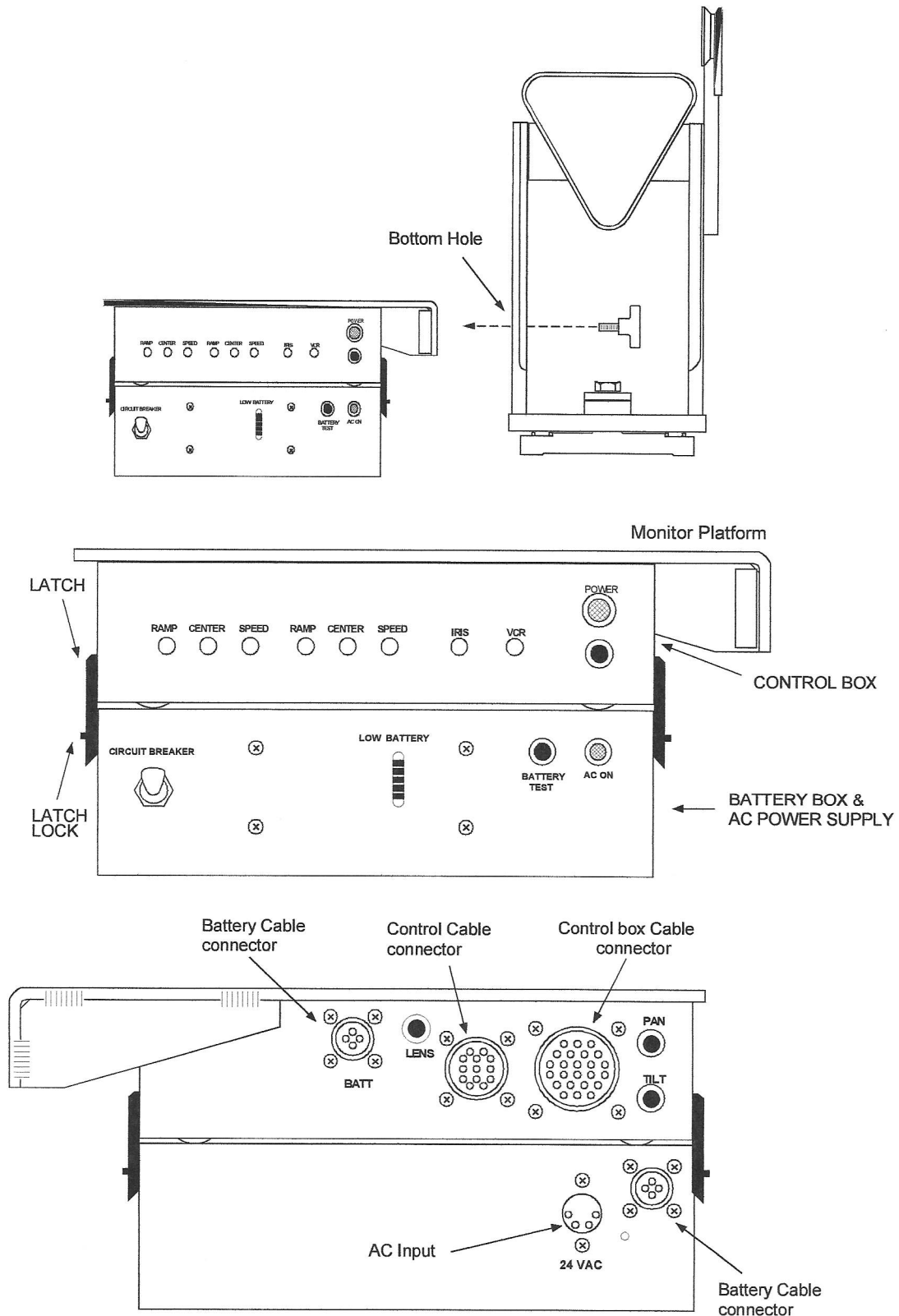

ELECTRONIC CONTROLS

1. Ramp: An adjustable acceleration ramp that cushions the start and stop of the pan and tilt motion. The amount of cushion is increased by rotating the "Ramp" knob clockwise.
2. Center: Sets the pan or tilt output voltage to zero. This is set at the factory and under normal circumstances does not require operator adjustment. If you observe the head moving without deflecting the joystick, it will be necessary to adjust centering.
 - a. Disengage the motors from 4 in. gears.
 - b. Adjust the RAMP to minimum and the SPEED to maximum.
 - c. Position the head so that you can observe the motor pinion.
 - d. Adjust the centering control until the gear stops moving.
3. Speed: Controls the maximum speed for pan and tilt. This makes the joystick less sensitive and is most useful for slow accurate moves.
4. Iris: Controls the iris.
5. VCR: Starts and stops the VCR providing your lens connector allows for this. Make sure the VCR switch on your lens is in the off position. Since most newer cameras require a momentary contact this is the type of switch that we have provided. If your recorder requires a maintained switch you will have to start and stop the recorder at the camera.

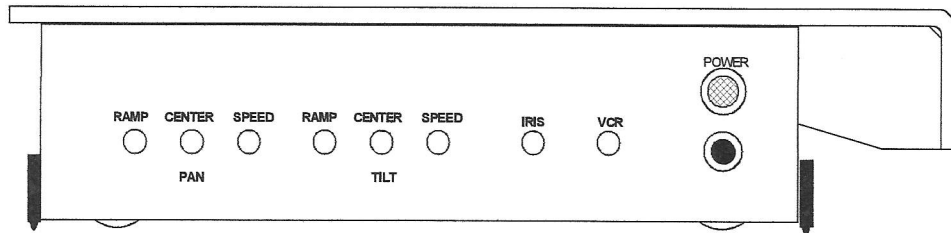

6. Lens: By pushing this switch you change to Canon or Fujinon. If your lens does not work properly this switch is probably in the wrong position.
7. Polarity: This switch enables you to change direction of the Joystick to whatever "feels" most comfortable to you. When you undersling the head it will be necessary to change pan direction.

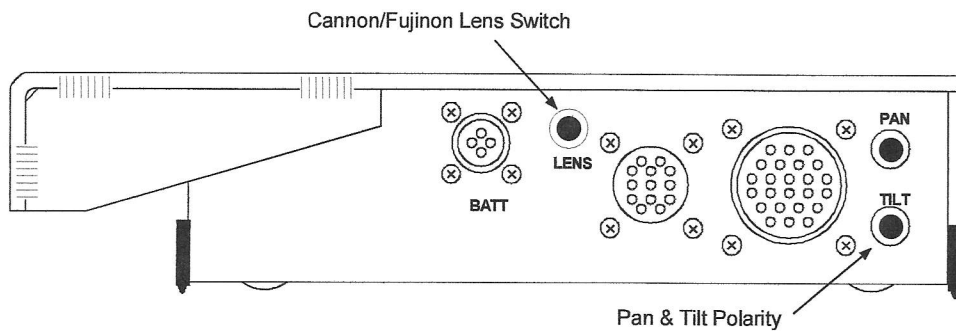

BATTERY OPERATION

Make sure the **Control Box** is turned off

1. To test the condition of charge, push the Battery Test button and the bar graph will light up. The Bar Graph is more of a Low Battery indicator than a Charge indicator. The best way to assure you have a full charge is to leave the charger on for at least 8 hrs.
2. Connect the Battery Cable between the Control Box and the Battery Pack.
3. **MAKE SURE ALL CABLES ARE CONNECTED** and turn on the Control Box power switch. The Power light will come on.

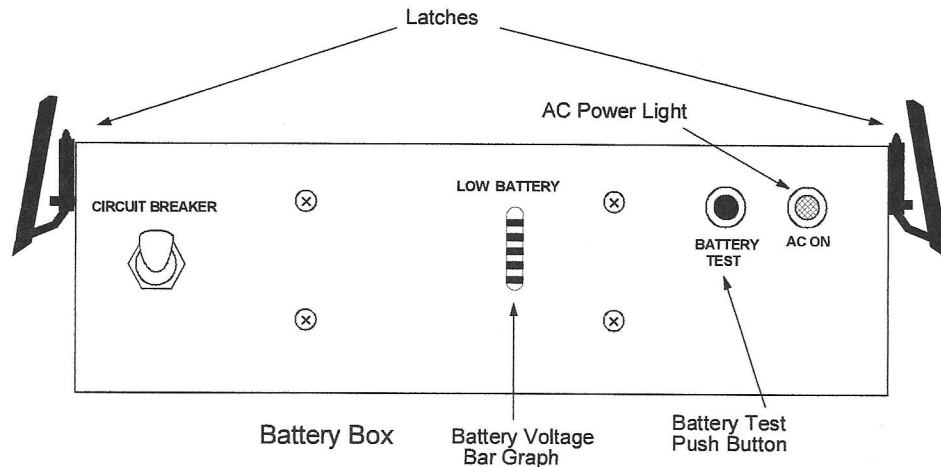

AC OPERATION

1. Connect the AC Transformer to the AC power source (120/220 VAC)
2. Plug the Transformer's XLR connector into the back of the Battery Box; the AC Power Light should come on.
3. The batteries are now charging and if the Battery Pack is connected to the Control Box the entire system is running on AC.

Circuit Breaker: The circuit breaker protects the batteries and must be in the on (up) position in order for the batteries to charge. Remember you will not be able to **charge your batteries** unless the **Circuit Breaker is on**.

The normal position of the breaker is "on", however there is one condition where you will want to turn the breaker off. This occurs when there is a **Short** or **Dead Cell** in the battery which will cause the Transformer voltage to be reduced to the point where the Head will begin to operate erratically. If you turn the Breaker off the batteries will then be separated from the rest of the circuit and the head will be operating on **AC Only**.

NOTE: The Battery Pack uses GELL CELLS not ni-cads. Gell cells can be charged indefinitely but must not be totally discharged.

ELECTRICAL CABLE ROUTING

THE UNIT SHOULD BE TURNED OFF BEFORE MAKING ANY CONNECTIONS

HEAD CABLE & CONTROL BOX CABLE

1. Run the Control Box Cable along the top of the jib tube and fasten it in place with the Velcro straps. The 24 pin Amp connector attaches to the Control Box and the 37 pin attaches to the Head Cable.
2. Connect the Focus Motor (red) and the Iris Motor (blue) using the 4 pin Switchcraft connectors.
3. Connect the Tilt Motor (blue) and Pan Motor (red) using the phono plugs.
4. Form a slack loop between the Head and the Jib arm. It may be necessary to slide the Head Cable along the jib tube in order to form the proper size loop.

CONTROL CABLE

1. Attach the Joystick and Zoom/Focus Handle to the weight bar.
2. Plug the 16 pin Amp connector of the Control Cable into the Control Box and route it down the Rear Tube section toward the weight bar.
3. Connect one end of the Control Cable (blue) to the Joystick and the other end (red) to the Zoom/Focus Handle.

NOTE: Cabling to the head can be routed through the holes provided in the Jib Center Section and the Front Tube Section. The cable will have to be routed while assembling the Jib

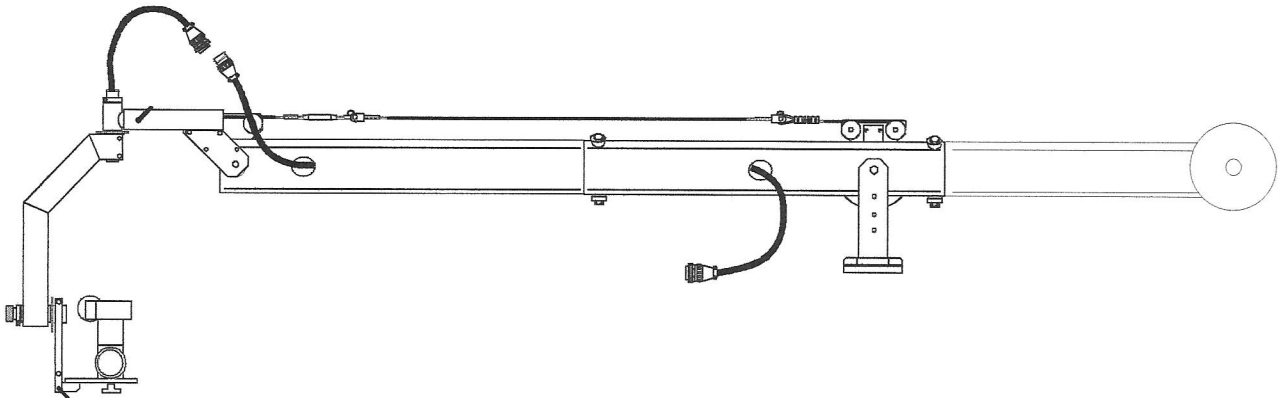

MODEL 4B ZOOM & FOCUS CONTROL

FOCUS TRAVEL
Sets the distance the Focus Servo will rotate and prevents the servo from hitting the lens stops.

FOCUS DIRECTION

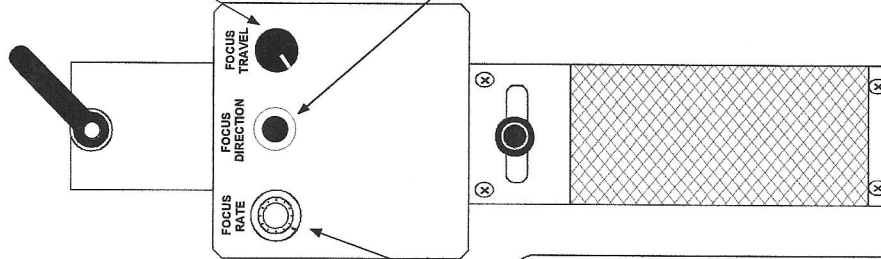

FOCUS RATE
Is used when switching between focus set points. It is a ramping control that controls the elapsed time to perform the focus.

ZOOM RATE
You can slow the maximum speed of the zoom with this control.

ZOOM
The zoom is controlled in the usual way with a rocker on top of the handle.

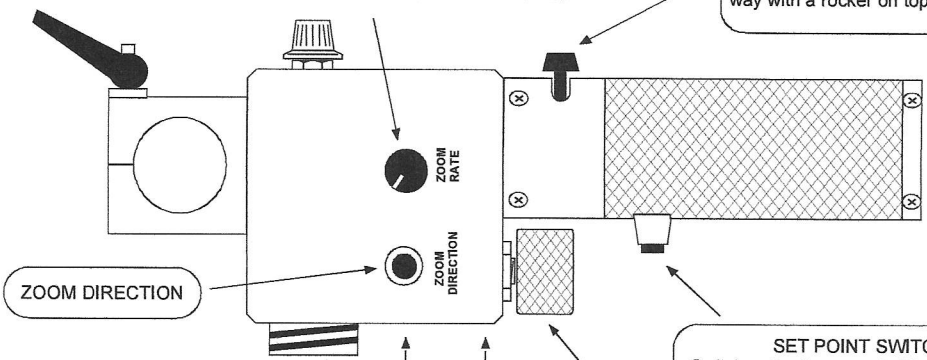

ZOOM DIRECTION

SET POINT SWITCH
Switches the focus control from the Focus Knob to the Follow Focus Box. This allows you to rack focus between two set points.

DUTCH CUBE

FOCUS KNOB

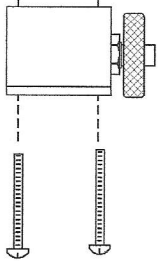

HOW TO ELIMINATE ZOOM CREEPING (4B controls)

There are two possible situations that can cause a creeping zoom problem. One is that the lens switch on the back of the control box is in the wrong position and the other is due to natural variations from lens to lens. Lens to lens variation can be corrected by adjusting a trim pot inside the Zoom Handle. It is extremely important that the lens switch be put in the correct position before the trim pot is adjusted. Please follow the instructions below to insure proper setup.

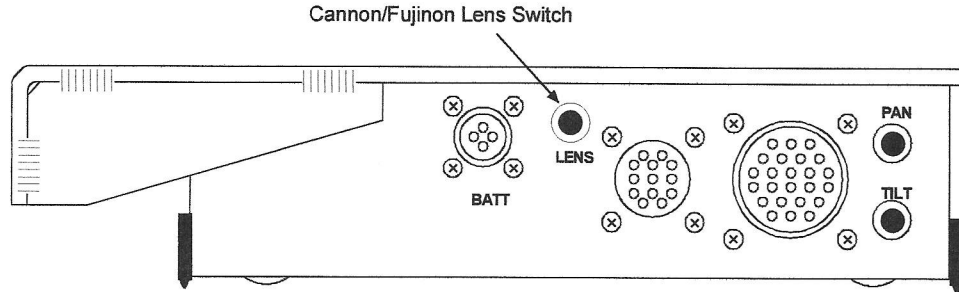

Lens Switch

1. Turn the camera on and observe how the lens responds. Rotate the Zoom Rate from minimum to maximum. If you can zoom the lens in and out using the Zoom Rate control then the lens switch is in the wrong position.
2. Once the lens switch is in the correct position the lens should work normally..

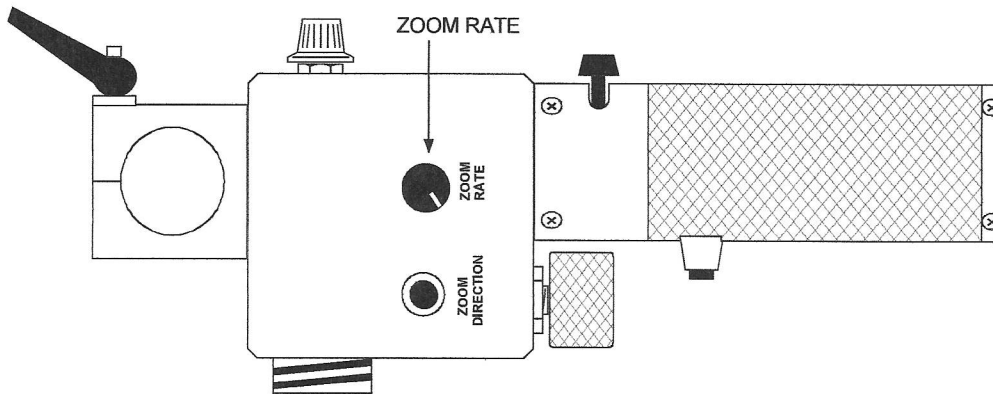

Always make sure the lens switch is in the correct position before you adjust the centering trim pot.

1. Turn the Zoom Rate Control all the way up
2. Remove the second (larger) set screw behind the zoom rocker, and locate the trim pot.
3. Use a small slotted screwdriver to adjust the pot until the creeping stops. Reinstall the set screw making sure not to screw it in so far that it drops inside the handle

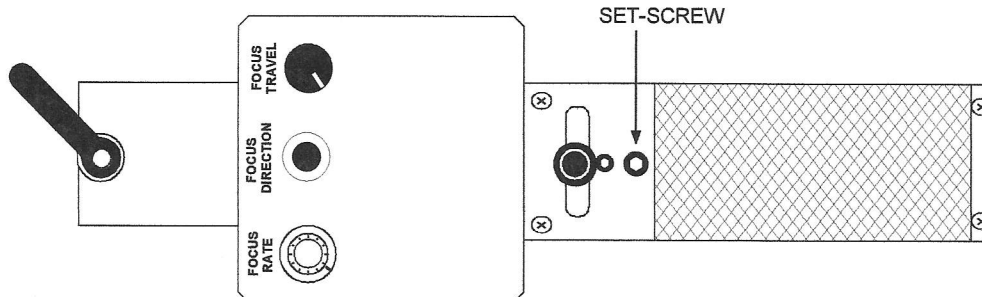

QUIETDRIVE LUBRICATION

The following instructions describe the proper lubrication of the QuietDrive gear motor. To prevent belt slippage the belt must be coated with some type of belt dressing. The critical point that must be remembered is that grease must not get onto the belt and you must not put so much grease into the gearbox that it gets thrown on the belt.

BELT DRESSING

We have found that JP1 Chain Lube (blue can) works the best as a belt dressing. This substance becomes very tacky without gluing the belt to the pulleys as some of the regular belt dressings tend to do.

1. Remove the Motor, the Pulley and the belt from the gearbox. If the belt has been slipping thoroughly clean the pulleys and belt with alcohol.
2. Coat the Belt and the grooves of the Pulleys with the dressing. Set these parts aside to dry for about 30min.

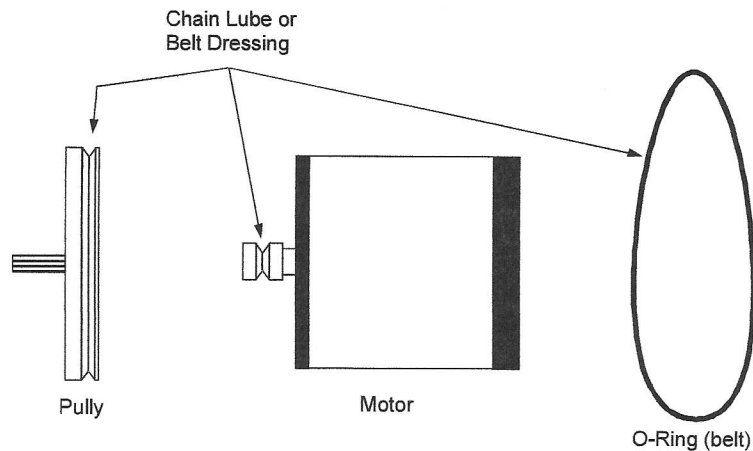

3. Mount the motor to the gearbox with the two 4-40 Philips screws and slide the tiny washer onto the Pulley Pin.
4. Add a small amount of grease to the Pulley Pin, slide the tiny washer onto the pulley pin, then add another small amount of grease to the Pulley Pin and slide the Pulley onto the Pulley Pin.
5. Run the Belt between the two pulleys taking care not to allow grease onto the Belt from the pins.

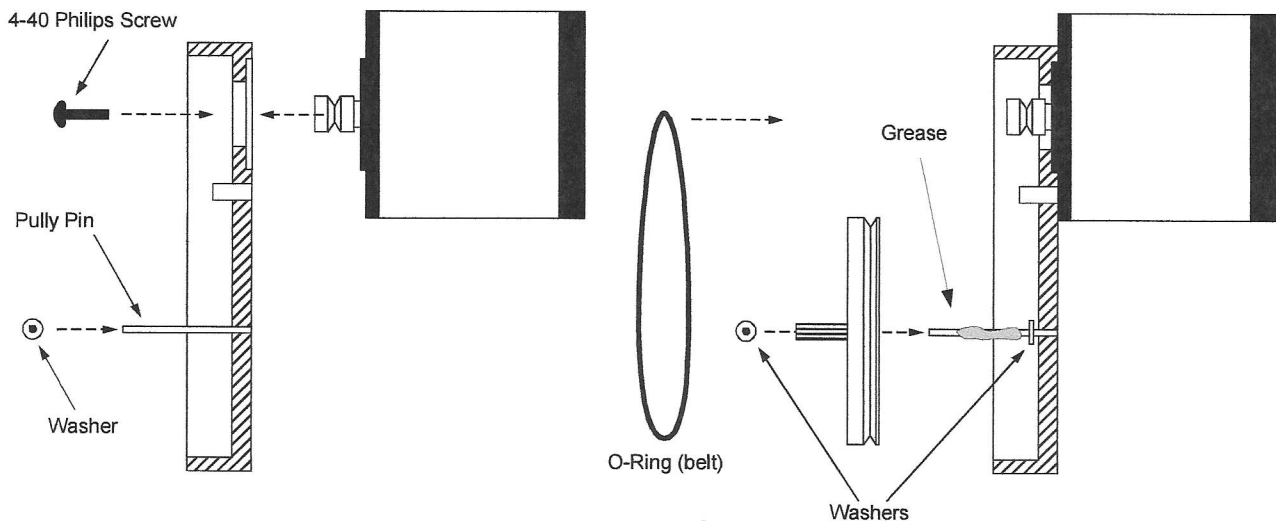

5. Add the thin washer to the Shaft Pin.
6. Place grease into the hole in the rear of the Shaft and grease the teeth of the Gear. Push the Shaft onto the Shaft Pin. It will be necessary to push until the Shaft seats against the back of the gearbox.

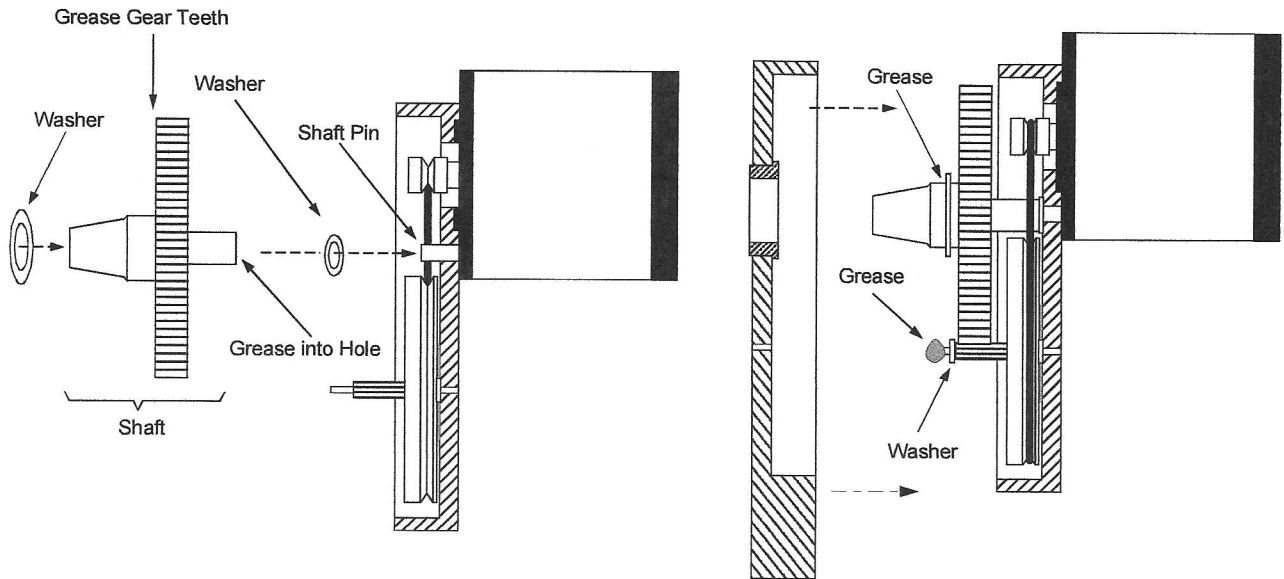

7. Place the tiny washer onto the Pulley Pin and grease the end of the Pin. Apply grease lightly to both sides of the large thin washer, install washer on the gear on the Shaft and close the gearbox.

NOTE: The lubricant used should be a non melting high temperature type of grease.
The Belt is an O-ring that is 2" OD with a 1/16" cross section.

CHARGING VOLTAGE ADJUSTMENT

1. The unit must be fully charged before making any adjustments.
2. Turn charger on and check voltage across pins 1,2 & 3 at the 4 pin AMP connector on the Battery Box.
3. Turn the Adjustment Pots to attain 14 Volts between pin 1 & 2 and 14 volts between 2 & 3.
4. After you have adjusted the two pots, measure the voltage between pin 1 & 3. It should be about 28 volts.

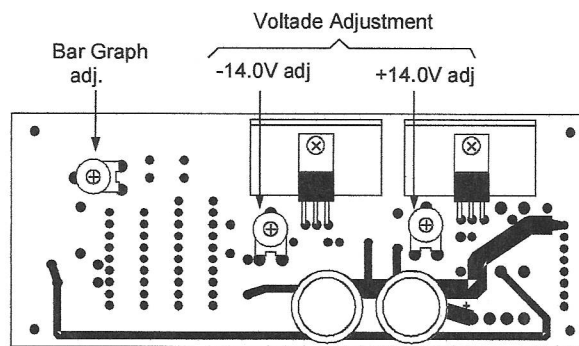

BATTERY PCBOARD

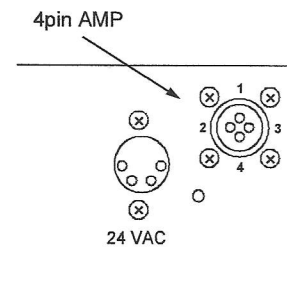

BATTERY BOX

CIRCUIT BOARD SET UP ADJUSTMENTS (Call Stanton Video!)

Focus Rotation Angle

1. The Angle Pots allow you to increase focus rotation. The factory setting is minimum (about 90 deg.).
2. To increase the Focus Rotation Angle turn the Angle Pot counter-clockwise.
3. Maximum is about 250 deg. If you over adjust the pot, the focus motor will continuously rotate in one direction.

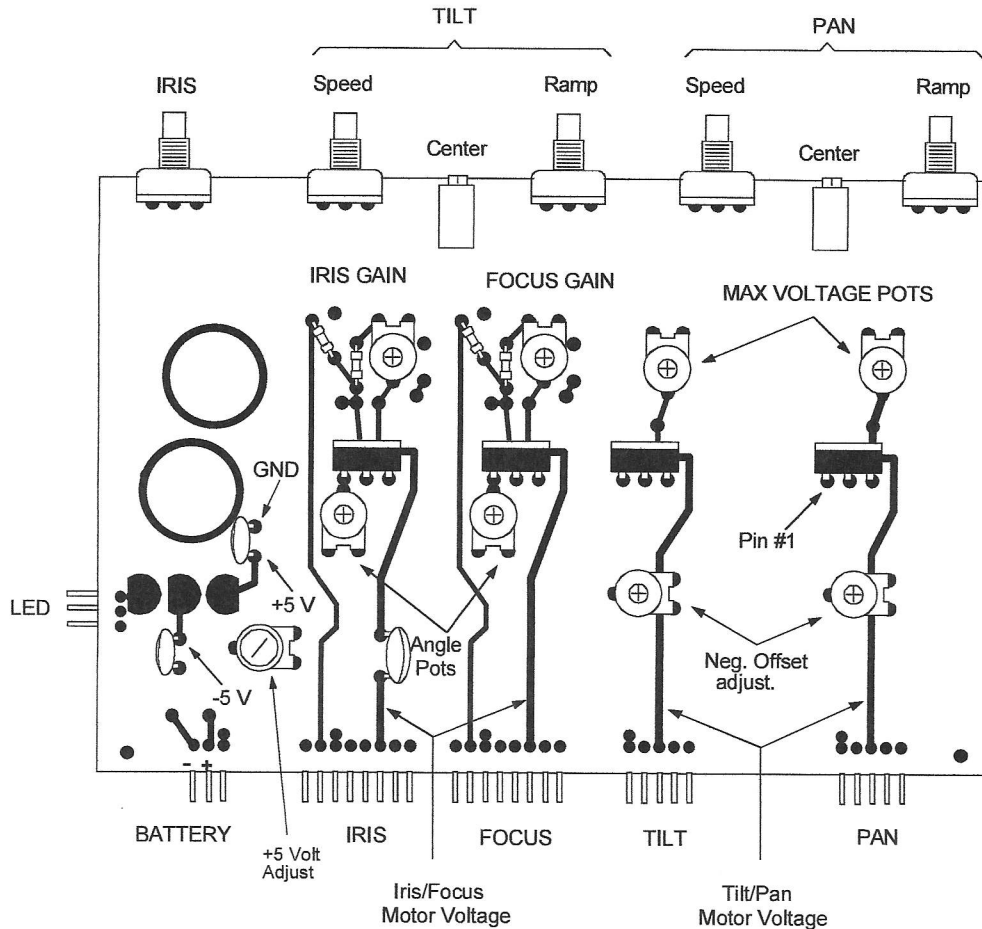

+5 Volt Adjustment

1. Connect a voltmeter from gnd to -5 V and measure the voltage. This measurement will usually be about -4.97 volts.
2. Connect the voltmeter from gnd. to +5 V.
3. Rotate the +5 Volt adjust. until the meter reads the same as the -5 V measurement. The goal is to make both the +V and -V read the same.

Negative Offset

1. Turn the Speed pot all the way down (counter clockwise).
2. Turn the Ramp pot all the way down (counter clockwise).
3. Connect Pin #1 of the Op-Amp to gnd. with a jumper cable.
4. Connect a voltmeter from Pan/Tilt Motor Voltage to gnd.
5. Rotate Neg. Offset Adjust. until the meter reads as close to Zero voltage as possible.

Maximum Voltage

1. Connect the voltmeter from gnd. to Motor Voltage.
2. Power unit from AC (connect to battery pack and turn on charger).
3. Deflect the Joystick (maximum deflection) of the axis being adjusted.
4. Rotate Max. Voltage pot until meter reads minimum voltage. Now rotate pot in the opposite direction and stop when the motor voltage ceases to increase

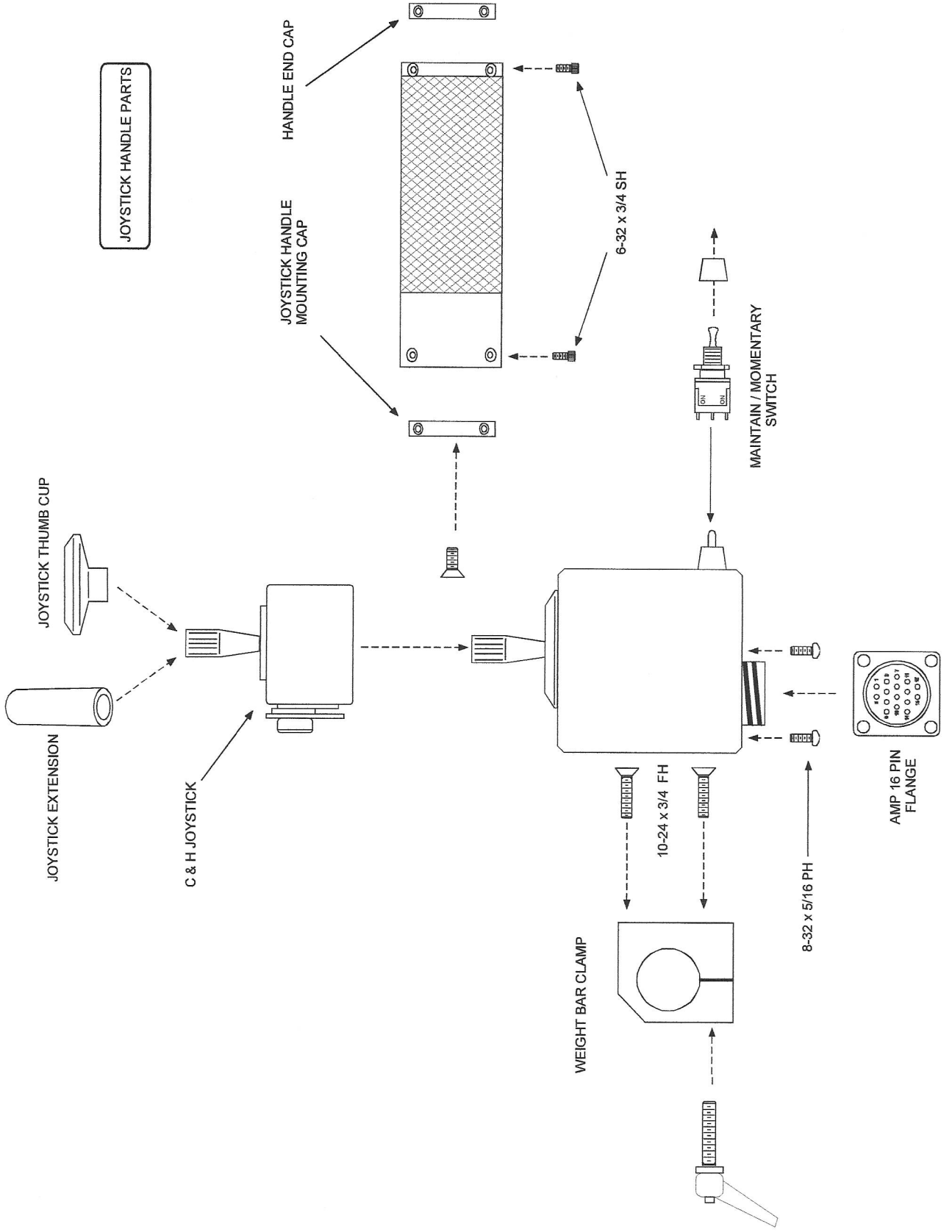

JOYSTICK HANDLE PARTS

JOYSTICK EXTENSION
 JOYSTICK THUMB CUP
 C & H JOYSTICK

JOYSTICK HANDLE MOUNTING CAP
 HANDLE END CAP
 6-32 x 3/4 SH

WEIGHT BAR CLAMP
 10-24 x 3/4 FH
 8-32 x 5/16 PH

MAINTAIN / MOMENTARY SWITCH

AMP 16 PIN FLANGE

**ZOOM-FOCUS HANDLE PARTS
W/SAKAE ROCKER POT**

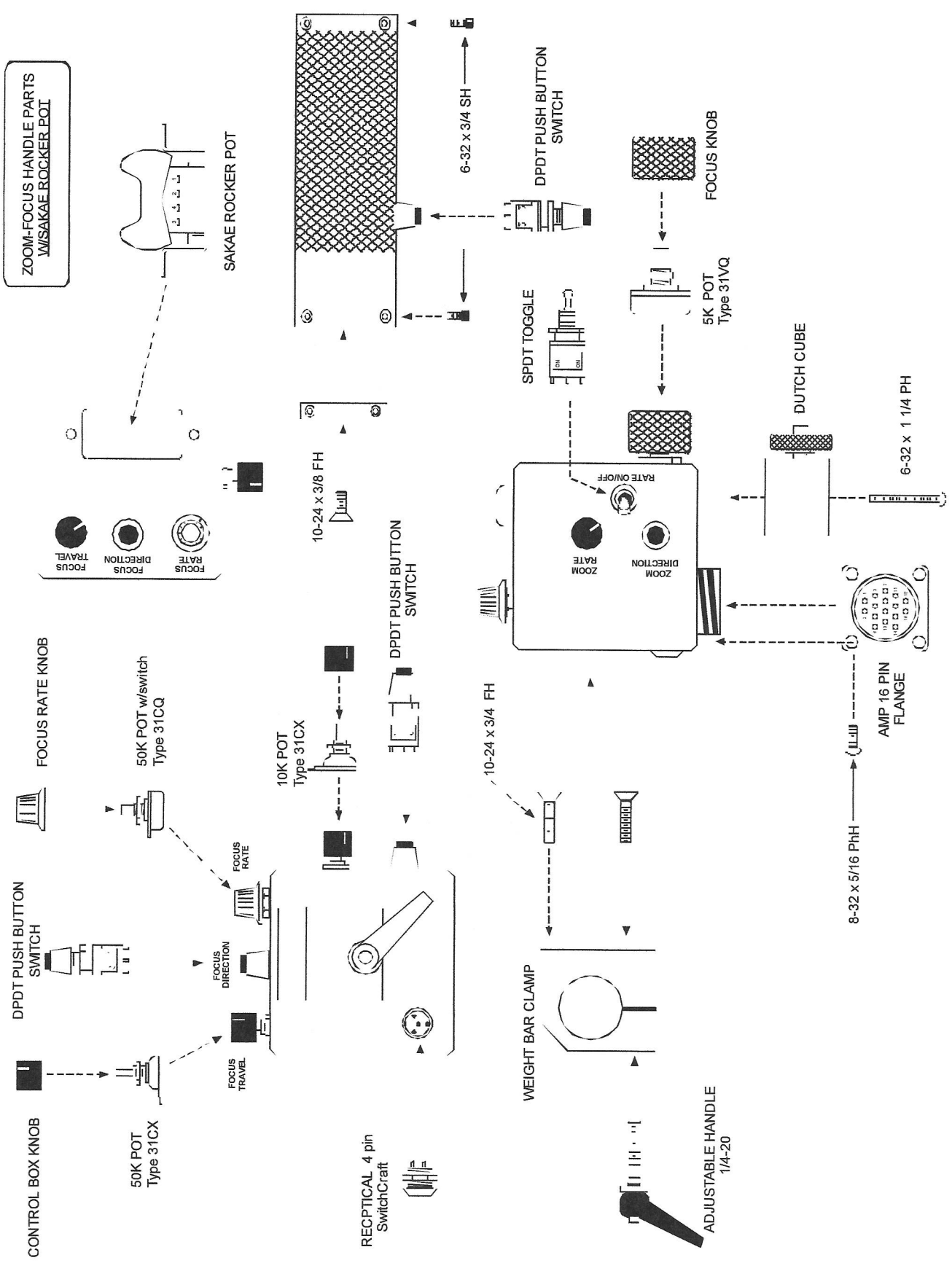

CONTROL PC BOARD

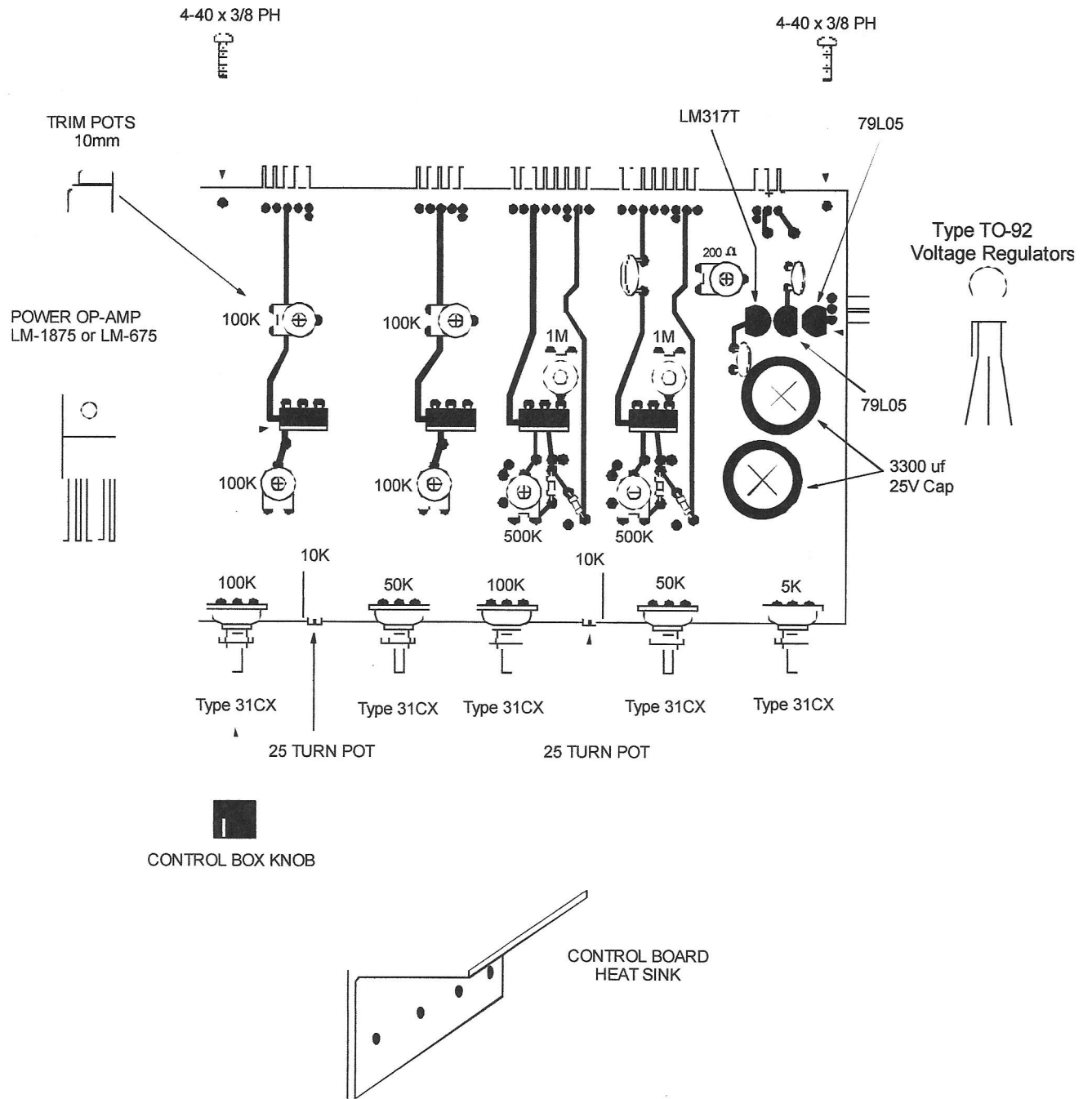

BATTERY BOX PC BOARD

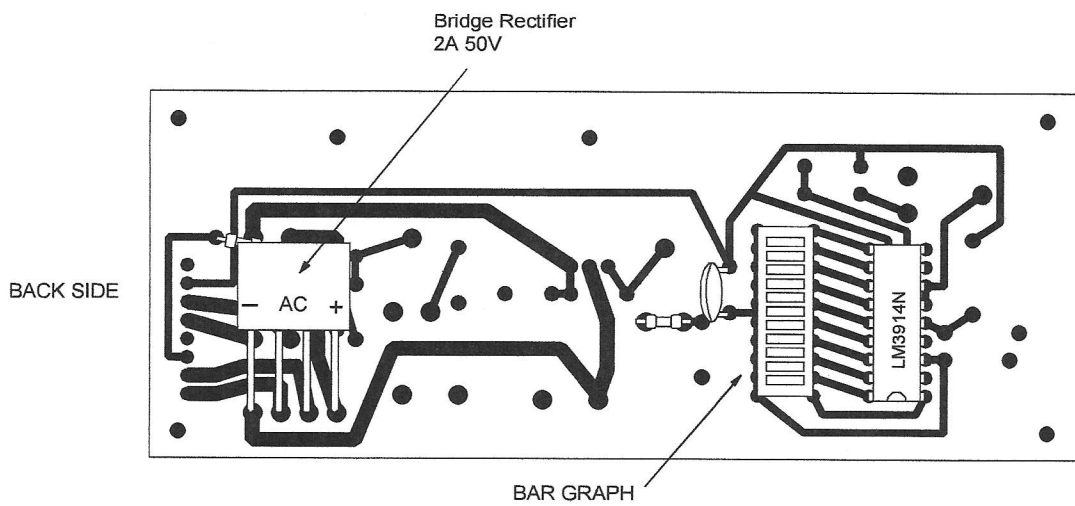
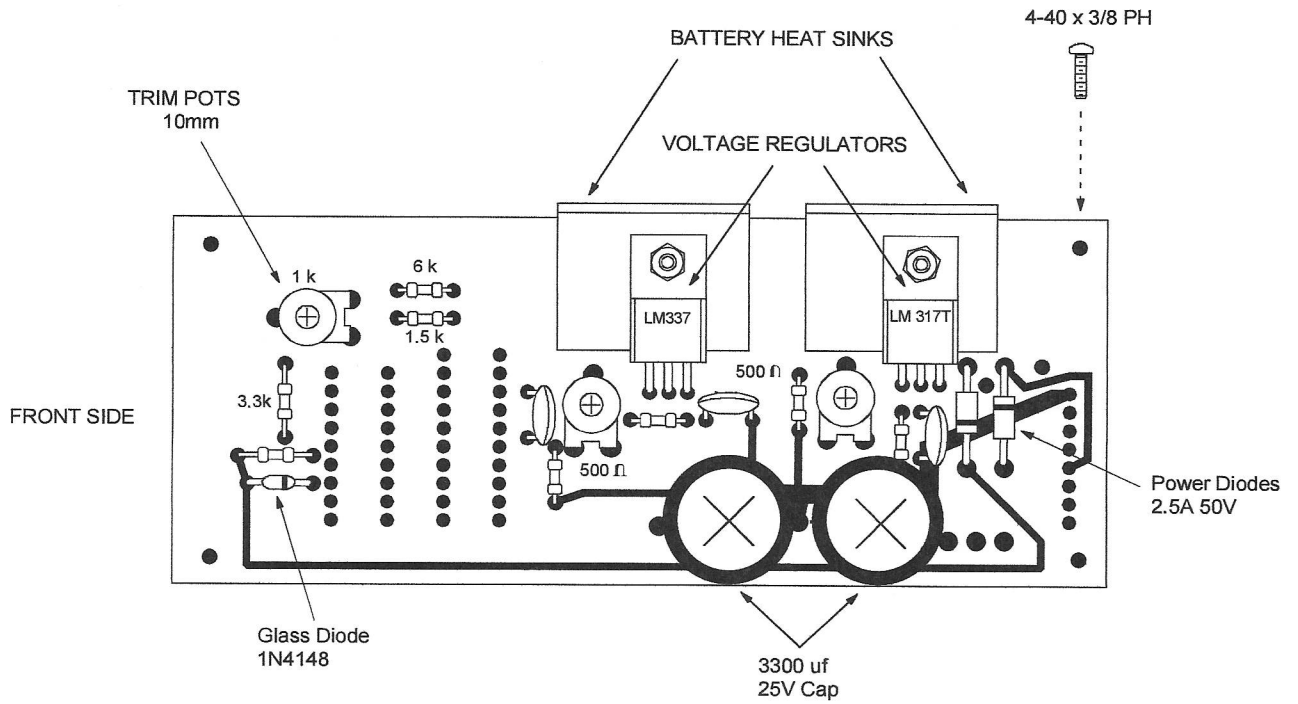

CONTROL BOX
BATTERY BOX
PARTS

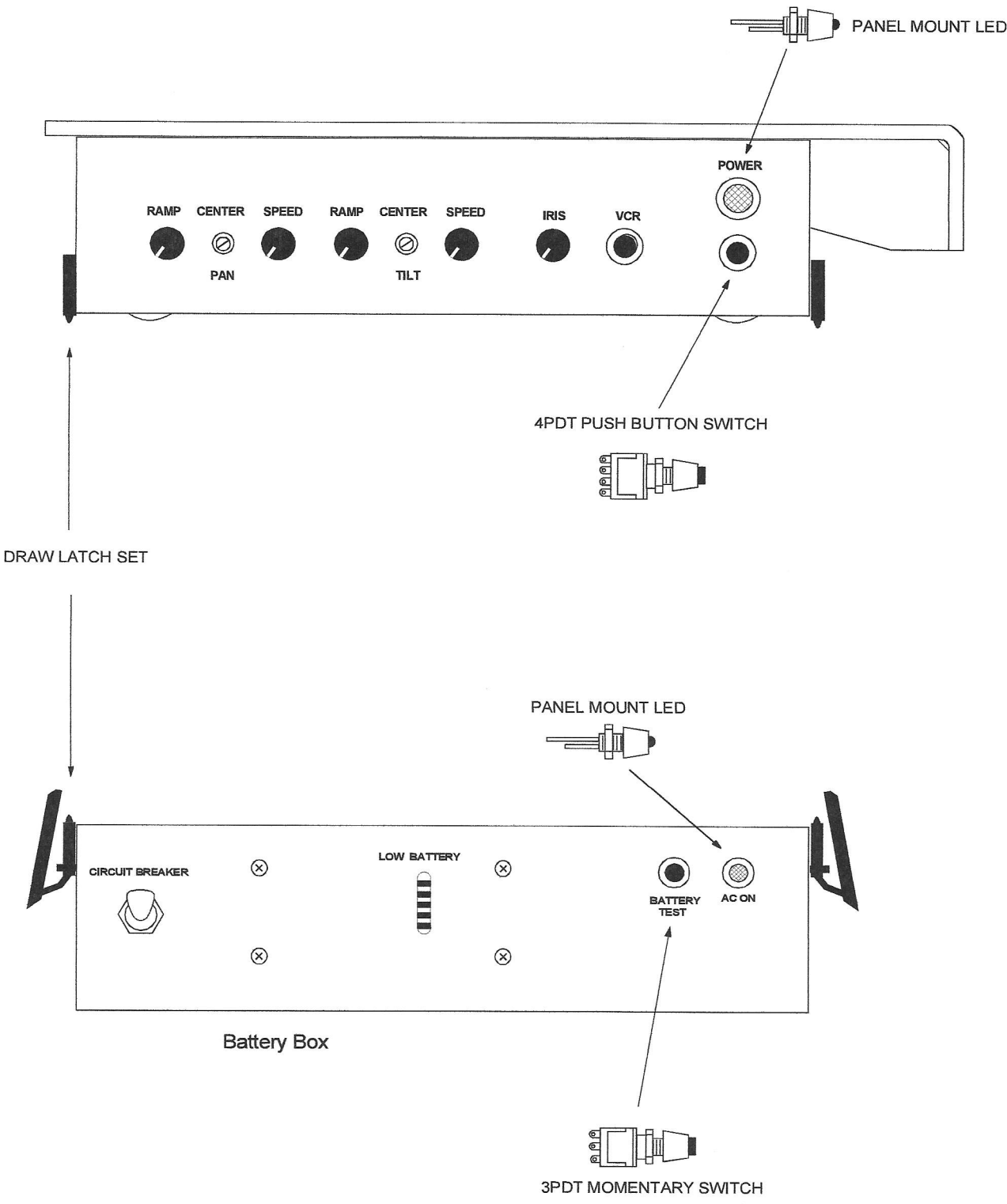

ΠΟΛΥΔΕΞΗΜΕΤΡΟ

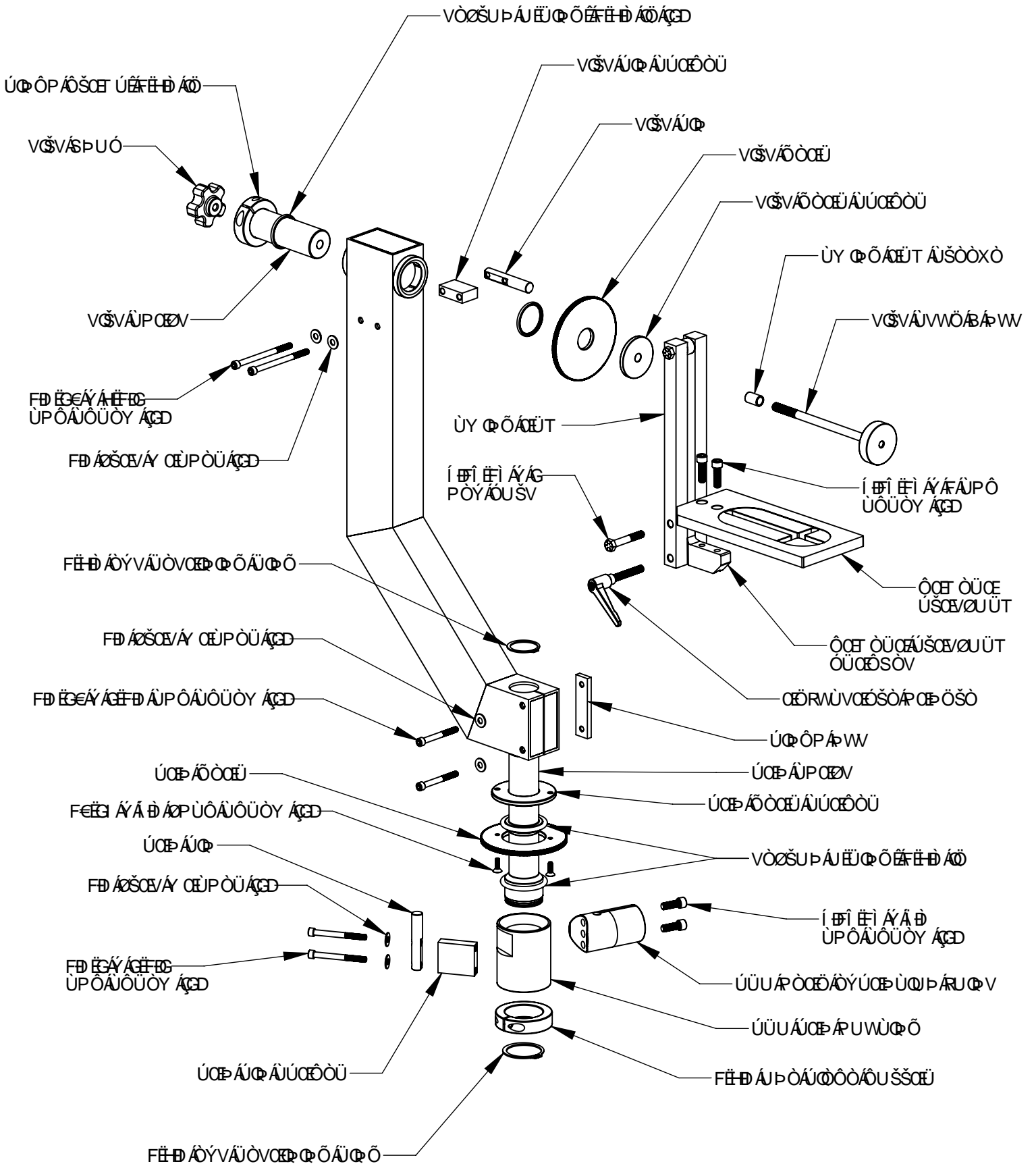

FRONT PARTS

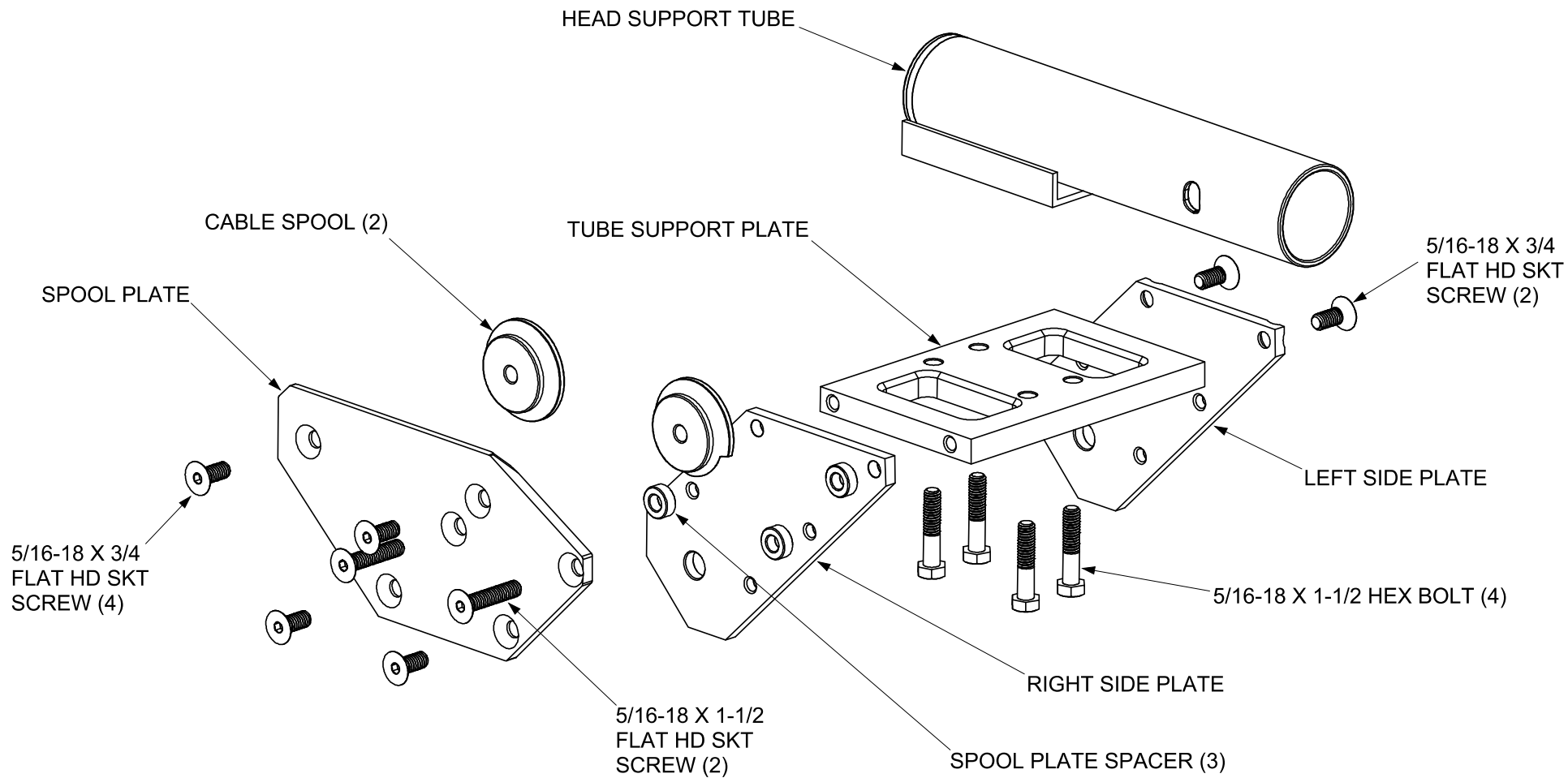

UPRIGHT PARTS

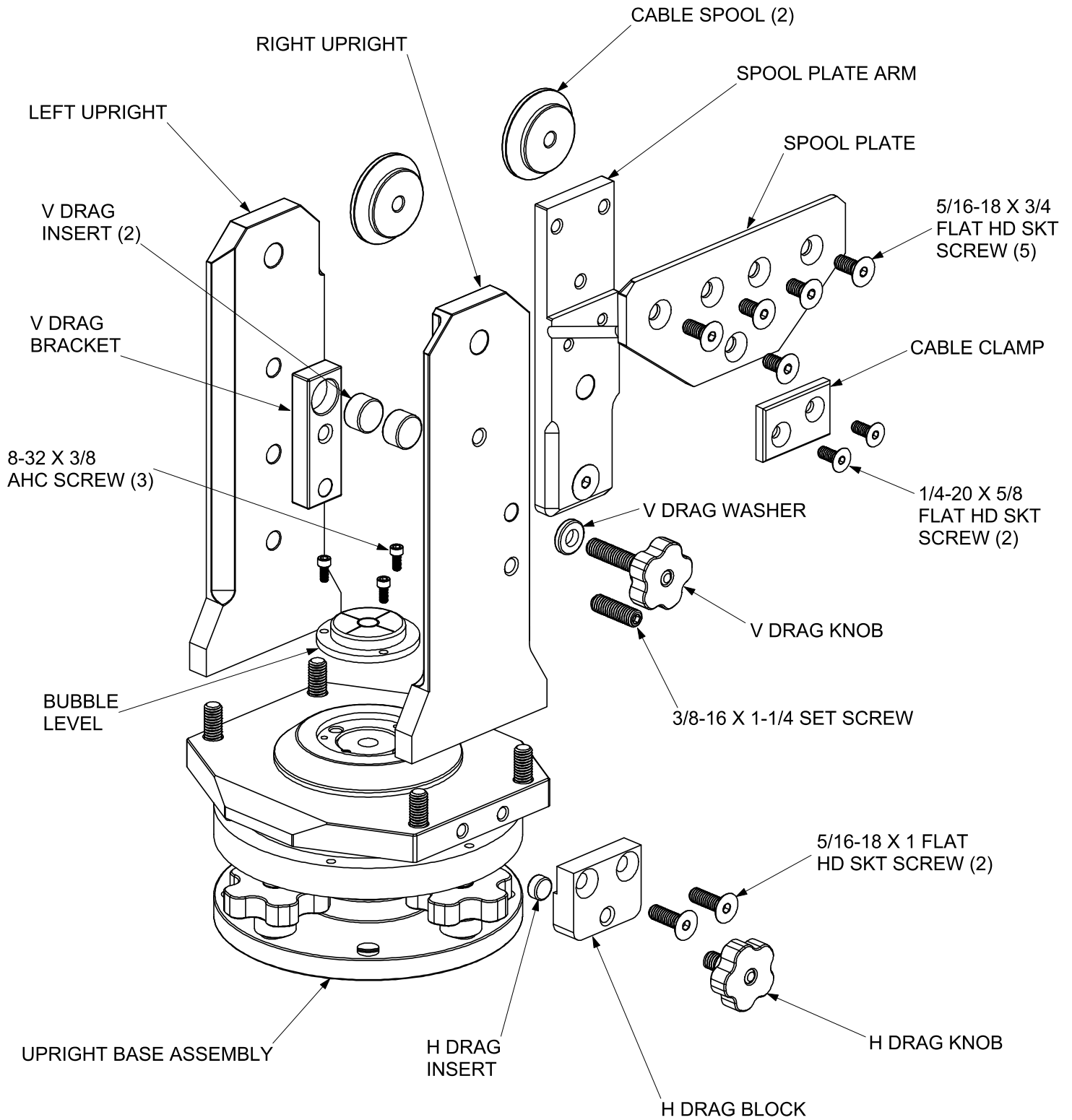

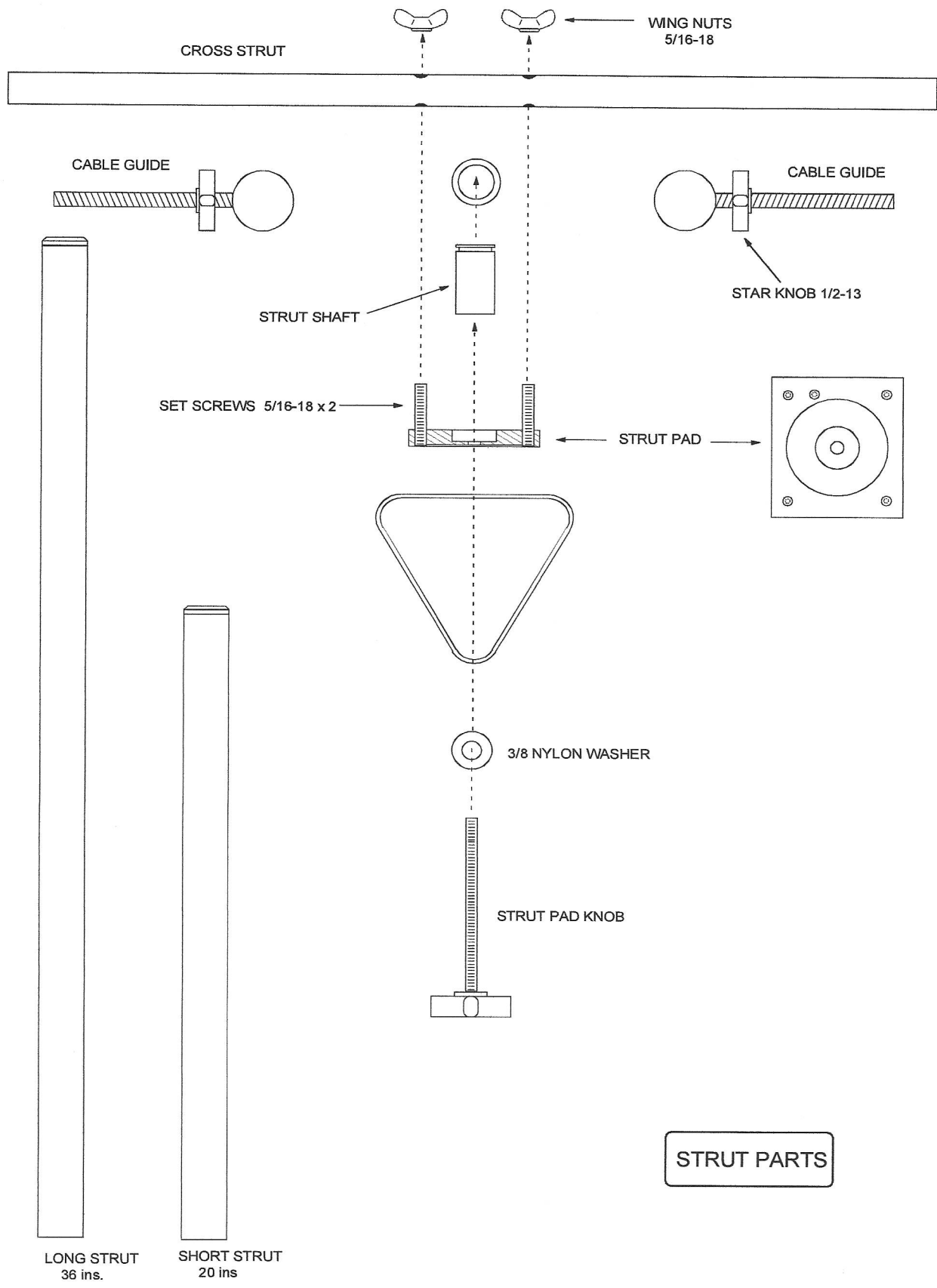

3/16 - 7x19

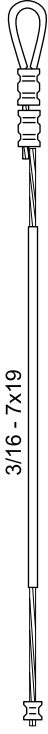

Copper Stop Crimp

REAR PULLY CABLE

3/16 - 7x19

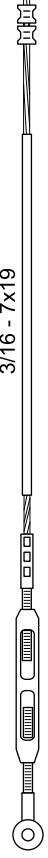

1/4-28 TURNBUCKLE

Copper Stop Crimp

FRONT PULLY CABLE

3/16 - 1x19



ALL PULLY CABLES

Toggle Jaw

ANCHOR SHACKLE
3/8 Alloy

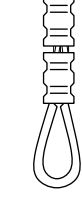
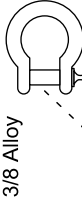

ANCHOR SHACKLE
3/8 Alloy

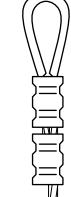

1/4 - 7x7

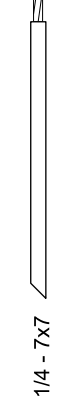

Giant & Giant Plus
Strut Cable

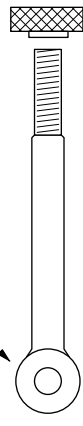

SUPPORT CABLES

5/8-11x7 EYE BOLT

5/8-11x7 EYE BOLT

STRUT CABLE

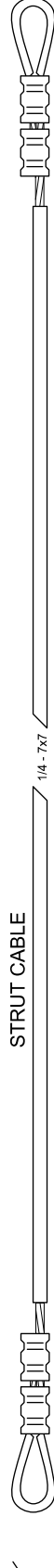

SUPER
GIANT

SIDE STRUT CABLE

3/16 - 1x19

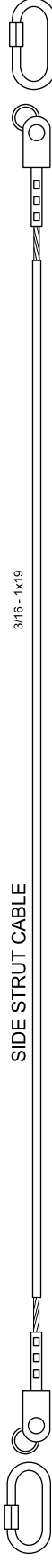

SIDE STRUT CABLE

3/16 - 1x19



CARABINER

CARABINER

CABLE CLAMP



STRUT CABLE #1

SUPER PLUS &
EXTREME

3/16 - 1x19

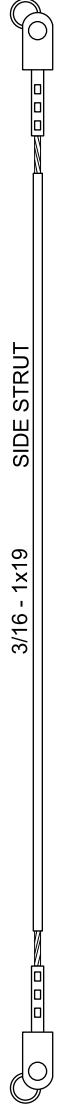

SIDE STRUT

3/16 - 1x19

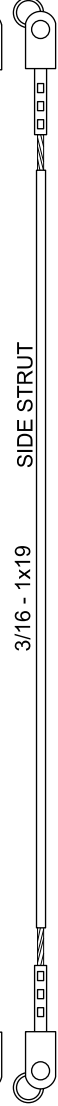

SIDE STRUT

STRUT CABLE #2

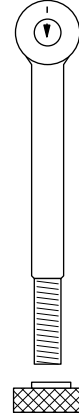

5/8-11x7 EYE BOLT

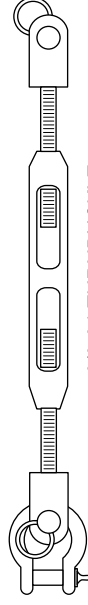

3/8-24 TURNBUCKLE



CARABINER

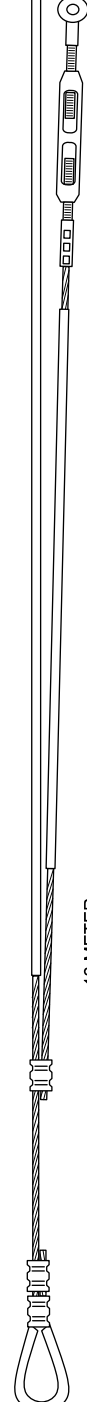

12.METER
SIDE STRUT CABLES

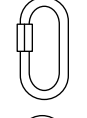

CARABINER

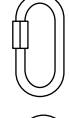
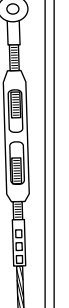
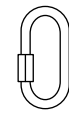

**SWINGING PLATFORM
&
CONTROL BAR**

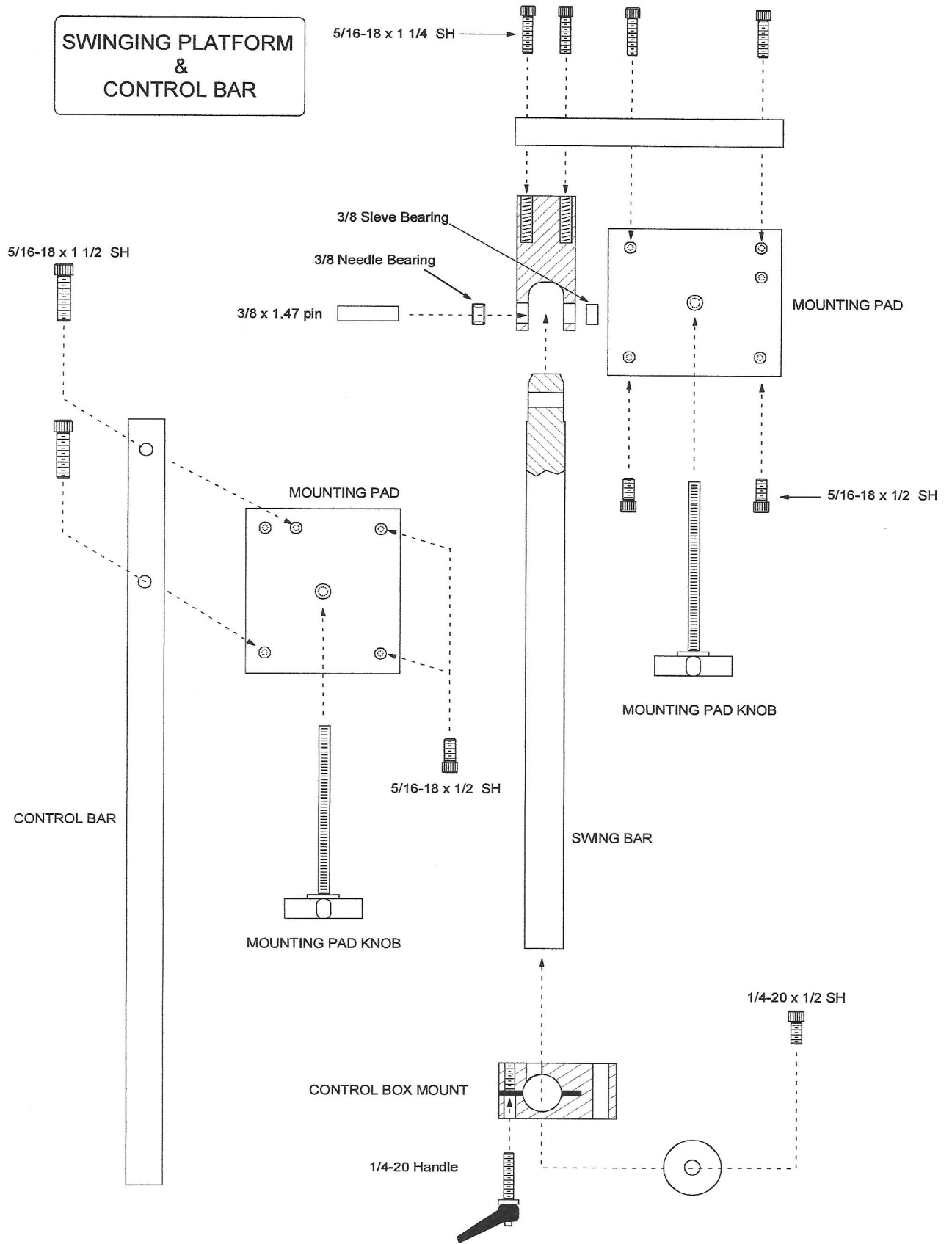

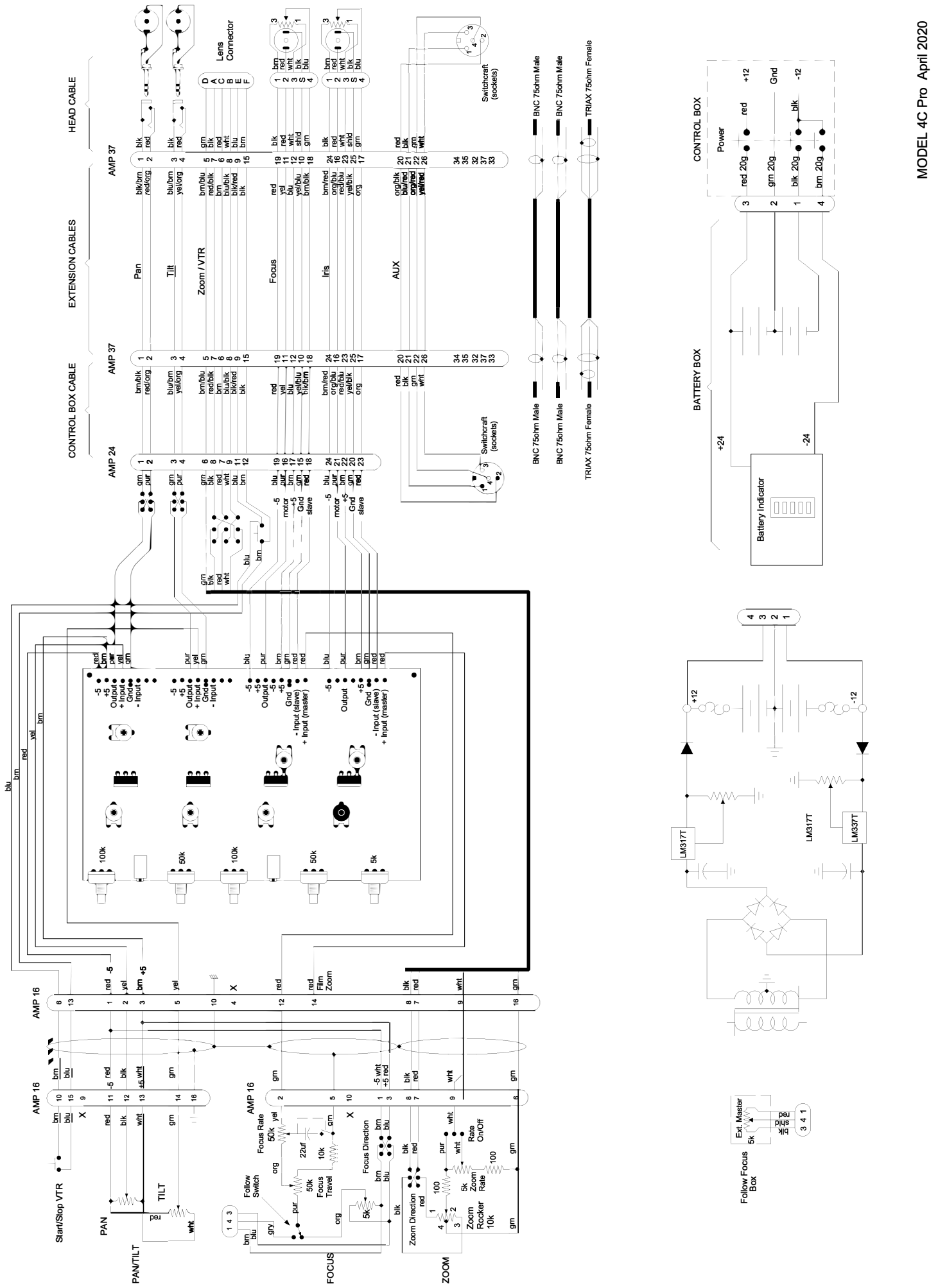

MODEL 4B ZOOM & FOCUS AND CONTROL CABLE

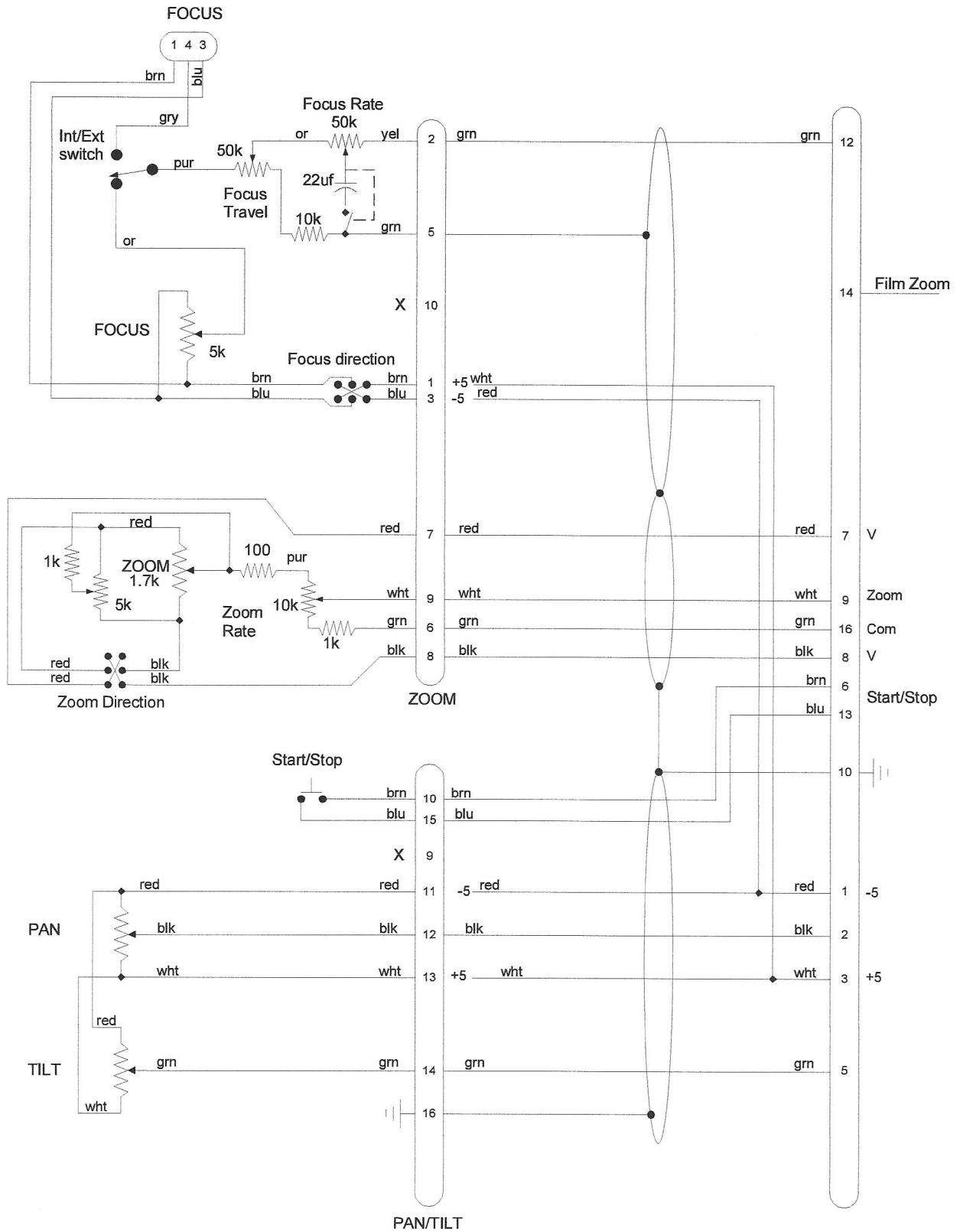

STANTON VIDEO SERVICES, INC.

2223 E. ROSE GARDEN LOOP
PHOENIX, ARIZONA 85024
602-493-9505

EC DECLARATION OF CONFORMITY

We, Stanton Video Services, Inc., herewith declares, that the following equipment complies with the appropriate basic safety and health requirements of the EC Directive based on its design and type, as brought into circulation by us. In case of alteration of the equipment, not agreed upon by us, this declaration will lose its validity.

Equipment Description: Stanton Remote Head Kit System
Stanton Mini Remote Head Kit

Equipment Type: Model No. 4 (including 4A, 4B and 4C)

Applicable EC Directives: EMC Directive 89/336/EEC
Amendment 92/31/EEC

Applicable Harmonized Standards:

EN 55022, Class B Limits and methods of measurements of Radio interference characteristics of information technology equipment.

EN 50082-1 EMC generic immunity standard Part 1: Residential, Commerical, Light Industry. IEC 801-2, IEC 801-3, IEC 801-4

Applicable National Technical Standards and Specifications: None Applicable

Notified Body: None Applicable

The CE Marking has been affixed on the equipment according to Article 10 of the EC Directive 89/336/EC.

Dated this 15th day of October, 2004.

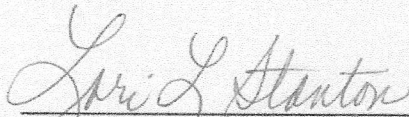

Lori L. Stanton, Secretary/Treasurer of
Stanton Video Services Inc.

DK

REPORT OF INSPECTION

CUSTOMER STANTON VIDEO

LOCATION 2223 E. ROSEGARDEN LOOP PHOENIX AZ

INSPECTOR DAN KACZMAREK

MANUFACTURER JIMMY JIB

MODEL NO. CAMERA BOOM TYPE 40'-12 METERS

SERIAL NO. N/A YR. OF MFG. 2002

UNIT NO. N/A TEST DATE April 24, 2002



Diversified Inspections/ITL

Post Office Box 39669, Phoenix, Arizona 85069, (602) 995-5800

DR-147

Form 018

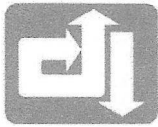

diversified inspections, inc.

Post Office Box 39669, Phoenix, Arizona 85069, (602) 995-5800 www.diusa.com

**BOOM & STAND FOR VIDEO CAMERA
ANNUAL SAFETY INSPECTION**

COMPANY STANTON VIDEO

CONTACT PERSON JIM STANTON

CONTACT TELEPHONE 602-493-9505

DATE OF INSPECTION 4/24/2002

MANUFACTURER JIMMY JIB

MODEL 40'-12 METERS VIDEO CAMERA BOOM & STAND

CAPACITY RATING 25 LBS

SERIAL NUMBER N/A

ASSIGNED LOCATION 2223 E. ROSEGARDEN LOOP PHOENIX AZ

DIOC NUMBER DR-147

INSPECTED BY DAN KACZMAREK

ISSUE CERTIFICATION YES NO

UNIT # 40'-12 METERS

BOOM & STAND FOR VIDEO CAMERA NON - DESTRUCTIVE EXAMINATION

A. VISUAL EXAMINATION	X = OK C = SEE NOTES N = N/A		
❖ Structural Assembly	<u> X </u>	<u> </u>	<u> </u>
❖ Hinge Points	<u> X </u>	<u> </u>	<u> </u>
❖ Attachment Points	<u> X </u>	<u> </u>	<u> </u>
❖ Safety Equipment	<u> X </u>	<u> </u>	<u> </u>
B. MAGNETIC PARTICLE EXAMINATION			
❖ Critical Weldments	<u> N/A </u>	<u> N/A </u>	<u> N/A </u>
C. ULTRASONIC INSPECTION OF PINS			
❖ Examine all Straight Pins	<u> N/A </u>	<u> N/A </u>	<u> N/A </u>
D. LOAD TEST			
Type	<u> FULL MOTION UP/DOWN & ROTATION </u>	<u> 80 LBS </u>	<u> PASSED </u>
	<u> STATIC TEST </u>	<u> 150 LBS </u>	<u> PASSED </u>
	<u> </u>	<u> </u>	<u> </u>
	<u> </u>	<u> </u>	<u> </u>
	<u> ROPE MEASUREMENT=.195" </u>	<u> X </u>	<u> </u>
	<u> ROPE MEASUREMENT=.254" </u>	<u> X </u>	<u> </u>

diversified inspections, inc.

P.O. Box 39669, Phoenix, Arizona 1-800-992-1111, Fax. 1-602-864-6975

CERTIFICATE OF LOAD TEST FOR VIDEO CAMERA BOOM AND STAND

Date: 04-24-02

Customer STANTON VIDEO

Location 2223 E. ROSEGARDEN LOOP PHOENIX AZ

Equipment Description: BOOM & STAND FOR VIDEO CAMERA

Manufacture: JIMMY JIB

Model 40'-12 METERS Serial Number N/A

Position	Boom Length	Radius	Boom Angle	Rated Load	Proof Load
ALL	40'0"	40'0"	0 - 85 DEG	25 LBS	80 LBS
0-DEGREES	40'0"	40'0"	0 DEGREES	25 LBS	150 LBS

Results of Load Test: Pass: X Fail

Comments PASSED LOAD TEST NO DISCREPANCIES NOTED.

The information provided in this report is the result of the specific testing and inspection procedures conducted by DIVERSIFIED INSPECTIONS, INC. ("DII") on the equipment and identified herein, as limited by the scope of work authorized by the customer (the "Test Results"). The Test Results reflect only the conditions of the components tested or inspected within the scope of work authorized. We have reviewed neither the maintenance records nor the actual use of the equipment before or after the date of the testing or inspection. NO ATTEMPT HAS BEEN MADE AND NO INFORMATION IS RENDERED WITH RESPECT TO ANY CONDITIONS OF THE EQUIPMENT OR ANY COMPONENT OTHER THAN AS EXPRESSLY STATED IN THE WRITTEN TEST RESULTS. SPECIFICALLY, BUT WITHOUT LIMITATIONS, NO INFORMATION, TESTING OR INSPECTION SERVICES ARE RENDERED CONCERNING EQUIPMENT DESIGN, SUITABILITY OF THE EQUIPMENT FOR ANY PARTICULAR PURPOSE OF THE FUTURE SERVICEABILITY OF THE EQUIPMENT. THE TEST RESULTS SHOULD NOT BE CONSTRUED AS STATEMENT THAT THE EQUIPMENT IS SAFE OR SERVICEABLE.

The information provided in this report is not a substitute for proper use, maintenance, modification, inspection and repair of the equipment, who shall assure safe operation of the equipment within its intended limitation. Furthermore, nothing in the Test Results should be construed as a recommendation for corrective action and DII has not and will not supervise corrective action of any condition found to exist, as such in the sole responsibility of the owner/operator and its is hereby expressly excluded from the scope of the work performed by DII. The Test Results are intended solely for informational purposes of the customer and should not be utilized or relied upon by any other person.

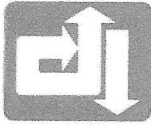

diversified inspections, inc.

Post Office Box 39669, Phoenix, Arizona 85069, (602) 995-5800

ANNUAL SAFETY INSPECTION FOR

MOBILE CRANES

Wheel Mounted - Telescoping Boom

OSHA 29 CFR
ANSI B30.5, B30.10

CUSTOMER STANTON VIDEO SERVICES, INC.

INSPECTION DATE JANUARY 16, 1998

CUSTOMER UNIT NUMBER JIMMY JIB

TYPE CRANE: Rough Terrain Truck Crane Other

MANUFACTURER/MODEL JIMMY JIB

SERIAL NUMBER _____

CRANE CAPACITY 50

BOOM LENGTH 30' JIB LENGTH _____ HOUR METER _____

ASSIGNED LOCATION PHOENIX, AZ

PERSON CONTACTED _____

INSPECTED BY RALPH GOODWIN

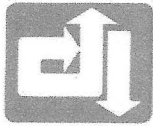

MOBILE CRANE LOAD/PROOF TEST

DATE 4/16/98

TYPE OF TEST: STRUCTURAL/TIPPING

FREE WEIGHTS _____

STATIC LOAD X _____

DYNAMOMETER USED: Serial Number _____

MAXIMUM RATED CAPACITY AS RIGGED 50 LBS _____

MAXIMUM MACHINE CAPACITY 50 LBS _____

TEST WEIGHT CALCULATIONS

	TEST #1	TEST #2
LOAD BLOCK WEIGHT	<u>0</u> _____	<u>0</u> _____
SLINGS AND SHACKLES	<u>0</u> _____	<u>0</u> _____
AUXILIARY WEIGHT	<u>0</u> <u>BOLTED TO GROUND</u>	
TEST WEIGHT	<u>55 LBS</u>	<u>172</u>
TEST WEIGHT	_____	_____
TOTAL WEIGHT	<u>55 LBS</u>	<u>172 LBS</u>
OUTRIGGERS [dn / up]	<u>DOWN</u>	_____
SIDE CAMS [in / out]	_____	_____
SIDE FRAMES [extended / retracted]	_____	_____

	TEST POSITION	BOOM LENGTH	RADIUS	ANGLE	RATED LOAD	PROOF LOAD
1.	<u>SLOPE 4</u>	<u>30'</u>	<u>30'</u>	<u>0°</u>	<u>50</u>	<u>105</u>
2.	<u>0</u>	<u>30'</u>	<u>30'</u>	<u>0°</u>	<u>50</u>	<u>172</u>

RESULTS OF LOAD TEST PASSED

DIVERSIFIED CRANE INSPECTOR RALPH GOODWIN

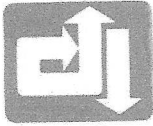

G. ROPE INSPECTION

	MAIN	AUXILIARY
1. Measured Size	1X.250,2X.192,1X.149	
2. Type		
3. Rope Spooling	N/A	
4. Damage Found	OK	

H. CRANE FUNCTIONS

1. Boom Up and Down	X
2. Swing Left and Right	X
3. Steering Left and Right, Circle, Crab, 2W/4W drive	N/A
4. Travel Forward and Reverse	N/A
5. Main Hoist - Hoist/Lower	N/A
6. Auxiliary Hoist - Hoist/Lower	N/A
7. Outrigger Beams - in/out	N/A
8. Outrigger Jacks - up/down	

I. LOAD BLOCKS

	MAIN	AUXILIARY
1. Manufacturer	N/A	
2. Model	N/A	
3. Capacity	50 BOOM TIP	
4. Serial Number	N/A	
5. Number of Sheaves	"	
For Rope Size	"	
6. Hook Type	"	
Throat Opening	"	
7. ID Tag and Weight Markings	"	
8. Hook Twist	"	
9. Hook Stretch	"	
10. Hook Wear	"	
11. Sheaves	"	
12. Bearings/Bushings	"	
13. Swivel and Thrust Bearing	"	
14. Pins and Retainers	OK	
15. Load Rope Dead End	N/A	
16. Safety Latch	"	
17. NDE: MT _____ VT <u>X</u>		

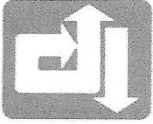

UNIT NO. _____ JIMMY JIB
1/16/98

DISCREPANCY PAGE

THE FOLLOWING DISCREPANCIES WERE NOTED DURING THE ANNUAL SAFETY INSPECTION OF THIS UNIT:

1 IV THERE WERE NO DISCREPANCIES NOTED AT THE TIME OF THE INSPECTION.

NOTE: • Manufacturer's recommendations as to frequent inspections and overhaul schedules must be followed to assure safe operation of this unit.
• Date of inspection. Placard affixed to unit at time of inspection.

REPORT RECEIVED: Jim Starbo

This page left blank for operator notes.